

Lightning Warning System MKIII

Installation and Operating Manual



LIGHTNING PROTECTION INTERNATIONAL PTY LTD
www.lpi.com.au

ABN 11 099 190 897



Lightning Warning System

LWS-MKIII

*Installation and Operating
Manual*

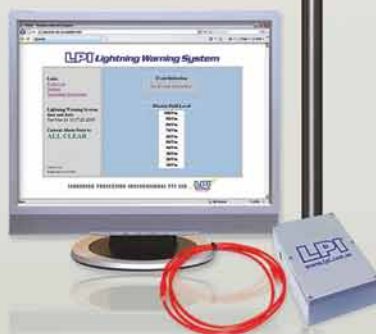

Contents

Contents	2-3
System Overview	4
What is it?	4
What does it do?	4
Console	5
LWS Sensor Assembly	5
Event Indication Levels	5
Warning Indication	6
Alarm Indication	7
All Clear Indication	8
Optional Range Extenders	8
Installation	9
Console Installation	9
Sensor Installation	9
Installation of Console / Console Antenna	18
Approved Sensor Locations	20
Range Extender Installation	21
Operation	22
Accessing the Interface homepage	22
Event Log	23
Saving in Internet Explorer	24
Saving in Firefox	25
Saving in Google Chrome	26
Changing the Settings	27
IP Address	28
Update Status	29
System Time	30
System Status	31
Alarm Reassert	32
All Clear Time Out	32
Indication Duration	33
Alarm Enable Times	34
All Clear Mode	35
User Name and Password	36
Restoring Console Factory Default Values	37



Document:
LWS-MKIII Installation
and Operating Manual
Lightning Protection
International Pty Ltd
© Copyright 2012 LPI

Contents

Establishing a LAN Connection to the LWS	38
Introduction	38
Setting up a Direct Connection Network for the LWS using Windows 7	38
How to put LWS onto a Network	45
Initially	45
If using DHCP follow these steps.....	45
If using a Static IP follow these steps.....	47
General Browser Settings	47
Relay / Alarm Output and Power Connectors	49
Maintenance Check Recommendations	49
Sensors and Range Extenders	49
Console	49
Supporting Documents	50
Optional Extras	50
Troubleshooting	51
Checking Power.....	51
Checking Network.....	51
Checking Communications to Sensor	51
Checking Siren Functionality.....	52
Error Messages.....	52
Specifications	Inside Back Cover

System Overview

What is it?

The LPI Lightning Warning System is a non-directional lightning detection instrument, designed to provide indication of nearby lightning strikes and significant changes in the local electrostatic field. The LPI Lightning Warning System MKIII provides the user with the ability to manage the lightning risk and to fulfil a duty of care to employees, customers and all related personnel. As occupational health and safety laws strengthen globally, senior management across a wide variety of industries and recreational pursuits are now faced with a realisation that they have a duty to warn individuals of the pending risks associated from lightning. Recent court cases have shown a dramatic change from the once acceptable “Act of God” defence, to a realisation that management now has a duty to warn.

What does it do?

On detection of a nearby lightning event or significant increase in the electrostatic field, the system will provide a Warning or Alarm to personnel that an event has occurred or is likely to occur. Detection and Alarm Indication (via a siren) is performed by the sensor unit, with results being sent wirelessly to the console for more detailed event Indication and logging.

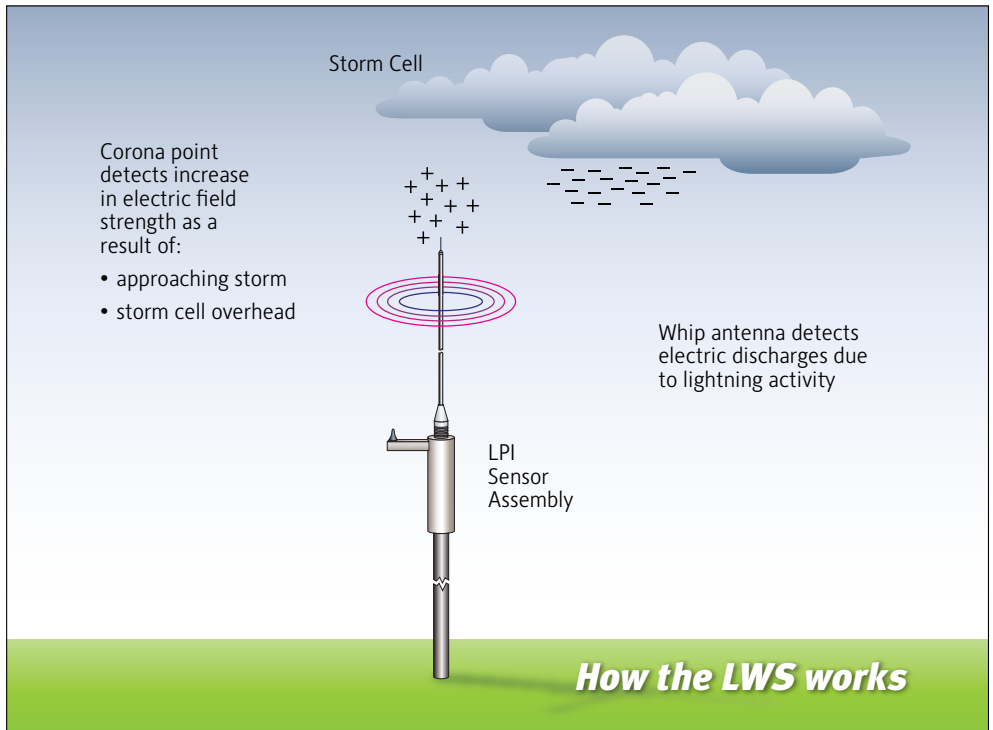

Console

The LWS MkIII Console provides the user interface to the LWS via its Webserver. It communicates with the sensor providing the user access to current lightning information.

This information includes details such as the current Lightning Warning Level, and recent lightning related activity such as Lightning Strikes and Electric Field Levels.

The Console is typically sited in a secure location where it can either be connected directly to a computer by cross-over Ethernet cable, or by straight-through Ethernet cable to a local network, allowing the user to access the relevant data and system settings. The Console has relay outputs for Alarm, Warning and All Clear indications suitable for switching contacts (Note: Only a small amount of current can be supplied by the Console alarm relay outputs, and therefore a siren or other indicator cannot be driven directly from the outputs).

LWS Sensor Assembly

The LWS Sensor Assembly (Microprocessor, Sensing Antenna, Alarm/Warning/All Clear Indicator and Earth Rod) is the integral component of the LWS system, it provides all decision making in regards to recorded lightning events and subsequent alerts.

The LWS Sensor Assembly is typically mounted at a suitable location at site and the monitoring of all lightning activity is controlled by an on board microprocessor. This works in conjunction with the sensing antenna to detect changes in the electric field and approaching lightning discharges. Depending on the intensity of the electric field or proximity of the lightning, the sensor provides an event indication via wireless communication to a receiving antenna and console unit which is positioned within 1 km line of sight of the sensor.

Each sensor also contains an Alarm/Warning/All Clear Indication device. Depending on customer preference this is provided by a siren, which allows the user to communicate situation events to all personnel in accordance with site safety policies and procedures. In the event of temporary communication loss between the Console and Sensor, indication of event detection still occurs at the sensor despite the communications loss.

Depending on the layout of the site and the area to be monitored, LPI can customize a solution.

LPI can also provide a suitable Mounting Pole (OD 70mm, ID 61.5mm) to mount the LWS Sensor Assembly to. If the Mounting Pole option is included, suitable locking bolts are also provided to keep the LWS Sensor Assembly secure.

Event Indication Levels

As the LWS MkIII sensor detects lightning activity or increases in the electric field, event indications are made at the Sensor and are communicated to the Console for processing. If the event falls within a predetermined level, the following indications are provided to the user.

Warning Indication

A Warning Indication occurs when either a far lightning strike or a low electric field is detected. Far lightning strikes are defined as lightning events that occur within a radius of approximately 10 to 25km of the sensor. Low electric-field events are defined as being when the local electric field rises above a level of 3kV/m. A Warning status provides the user with an indication that a storm is within a relatively close range and may move towards the area where the sensors are stationed. When a storm is within 25km it may arrive in the area in approximately 20-40 minutes.

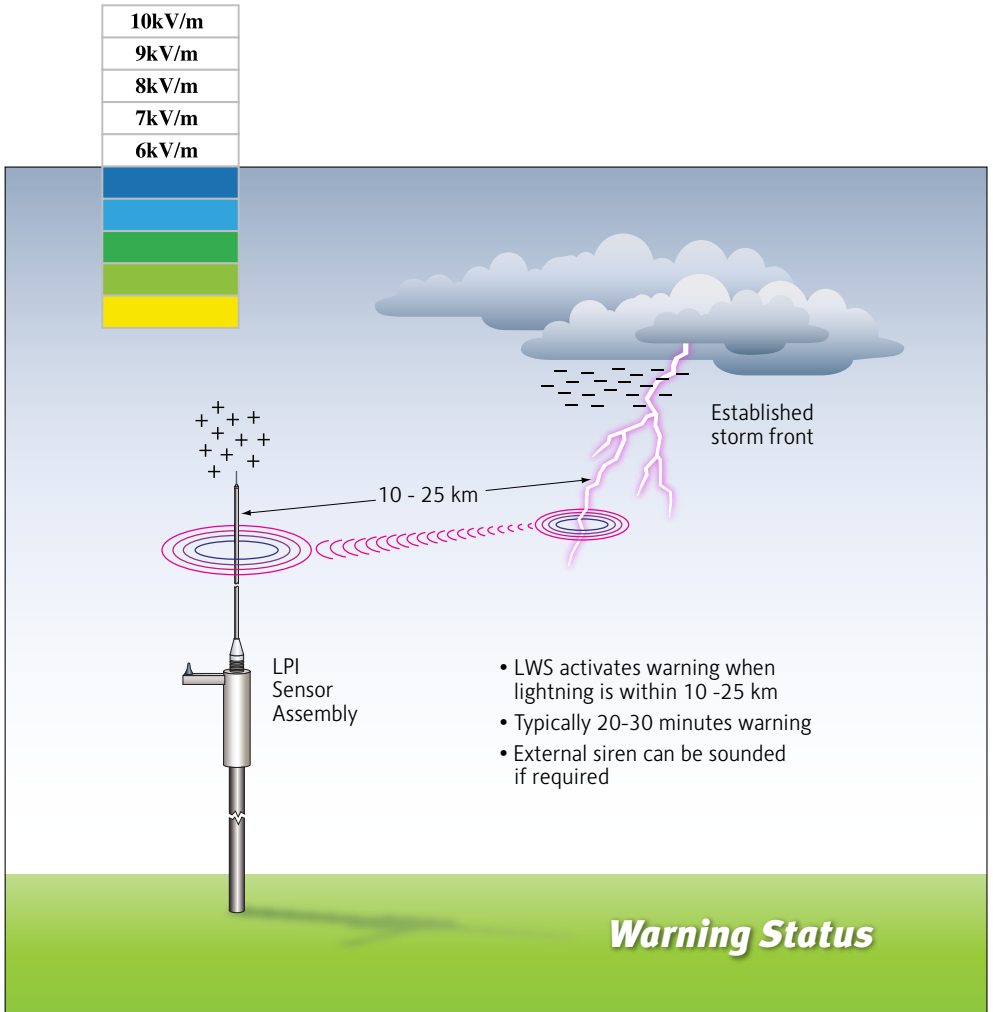

Alarm Indication

An Alarm Indication occurs when a near lightning strike or high electric field is detected. Near lightning strikes are defined as those being within a radius of approximately 8 to 10km of the sensor and could be close enough to pose a significant risk within approximately 10-15 minutes. High electric field events are defined as being when the local electric field rises above 7kV/m. An Alarm status provides to the user an indication that current activities at site should be suspended and shelter taken in accordance with established safety procedures.

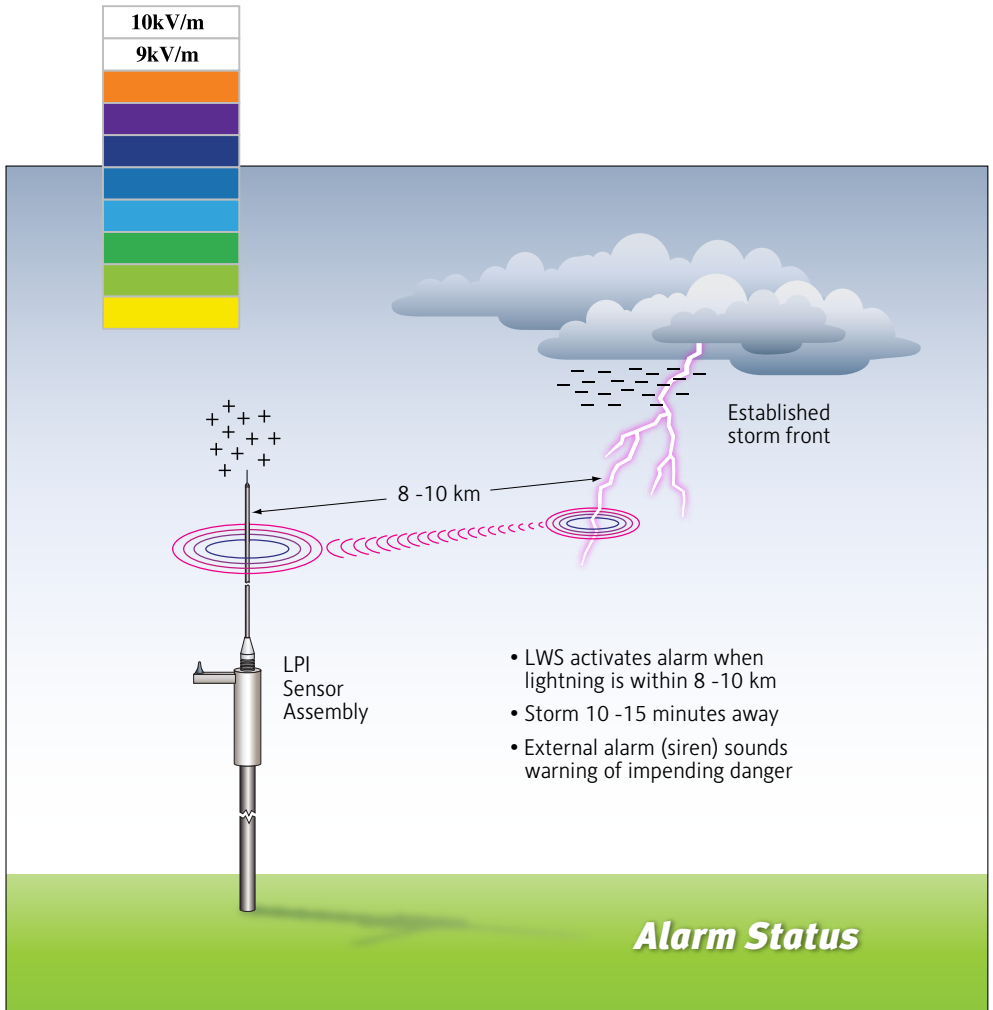

All Clear Indication

An All Clear Indication is given when no activity (far strikes, near strikes, low electric field or high electric field) has occurred within 10-30 minutes (programmable). After this period of no activity it is deemed safe to resume all activities.

*There is also a Quick All Clear version of the LWS, which will behave slightly differently, this will give an all clear indication after 10-30 minutes with no Near Strikes or High E fields.

Optional Range Extenders

In a standard LWS MkIII system, the Sensor must be within 1km and have direct line of sight to the Console Communication Antenna. If this is not possible, then important information about settings and recorded lightning events will not be transmitted.

However it is possible to use one or more Range Extenders to increase the distance between the Sensor location and the Console, allowing settings and lightning event information to be passed between the Sensor and Console.

Range Extenders work by being placed in positions that give <1km line of sight to both the Console Communication Antenna and the Sensor (or to another interim Range Extender).

Range Extenders can also be configured to act as alarm repeaters, turning on alarms at the same time as the Main Sensor and Console. This allows a greater area to receive warnings about lightning events. Range Extenders have no individual capability for detecting lightning events.

Up to 10 Range Extenders can be included as part of a system. These can be arranged in a mesh or line configuration. It is possible to have more than 1 Range Extender within <1km line of sight of another Range Extender, Sensor or Console without interference.

Range Extenders are available in either Package A (power supply) or Package B (solar panel) configuration.



Installation

Console Installation

The console should be situated in a secure location close to either the primary computer used to access the user interface, or to a router/network switch to allow for easy connection. This location should allow for a co-axial antenna cable to be connected to an “out-door” wireless antenna. The length of co-axial cable supplied is 2.5m long. The out-door antenna must also have line of sight to a sensor within a range of 1km. For multiple sensor systems the console antenna only requires line of sight to the nearest sensor less than 1km away.

A recent web browser, such as Firefox, Chrome or Internet Explorer, must be installed on a connected computer to view the web based user interface. Elements of the user interface may not work correctly using an old browser.

The console requires a 6Vdc power supply, the power supply is included and comes with an Australian 3pin to IEC C7. mains lead.

If required the customer is to supply an IEC C7 mains lead to suit their local mains power socket outlet type.

Sensor Installation

The Sensor Assembly will be provided in three separate parts; the upper sensor antenna, the sensor housing and copper earth rod. In an approved location (see section on *Approved Sensor Locations*), the procedure for Assembly of the Sensor Assembly is as follows:

- i) Insert the Corona Point Needle into the top of the upper sensor antenna and secure in place with the provided grub screw and hex key.

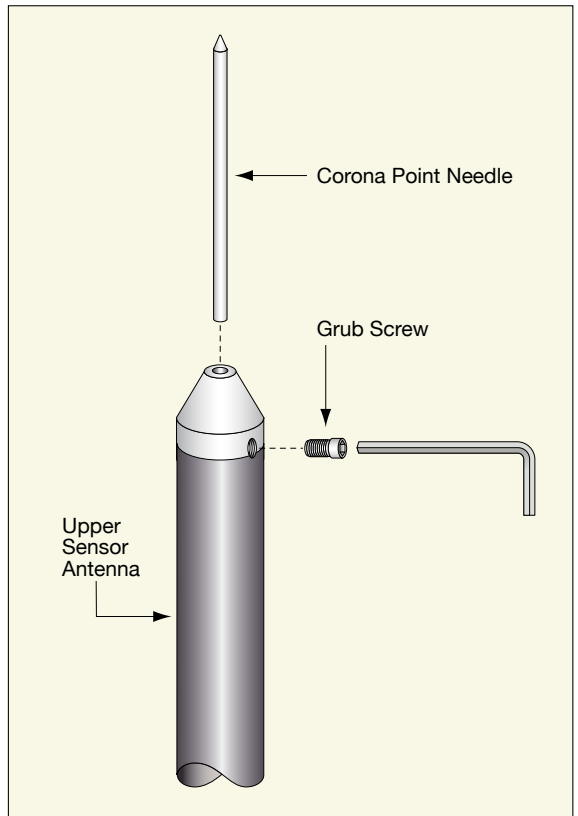

- ii) Screw the upper sensor antenna into the antenna base on the top of the sensor housing.
- iii) Ensure cabling for Alarm relay outputs (siren/ LED display), power input (12Vdc plug pack Solar Panel and Battery) and earth cable have been installed correctly, either up the centre of the mounting pole or through a hole in the side of the mounting pole.

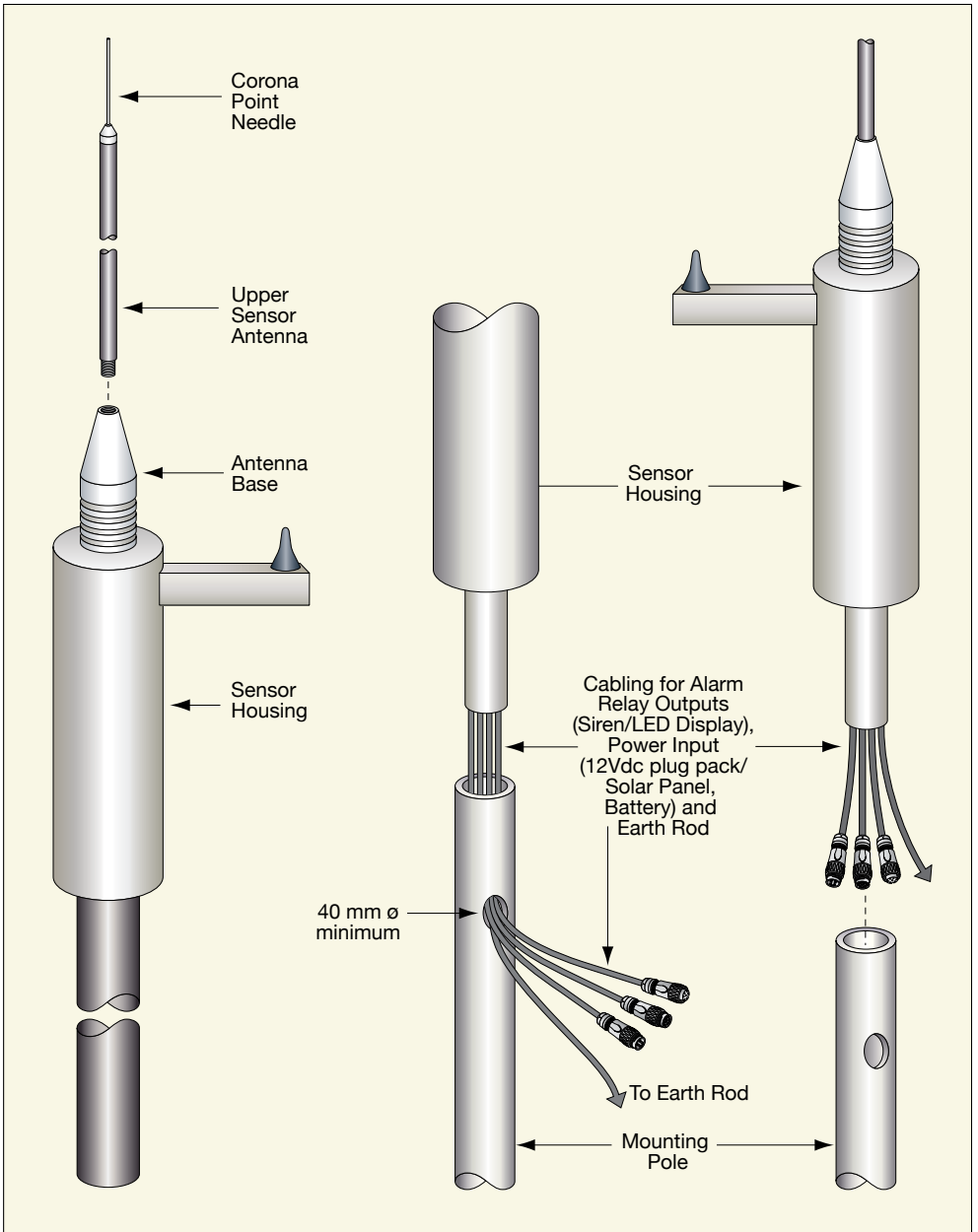

iv) Connect Alarm relay plug and socket and power input plug and socket.

Note: Ensure the supplied dust cap remains fitted to the remaining 7 pin plug (if not being used).

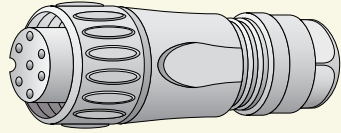

7 Pin Socket (Female)
Warning output from Sensor
(supplied with fitted dust cap)

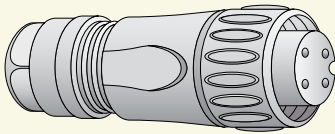

4 Pin Socket (Female)
From Power Supply

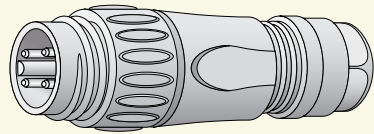

4 Pin Plug (Male)
From Sensor

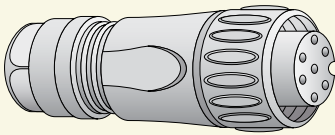

7 Pin Socket (Female)
To Alarm

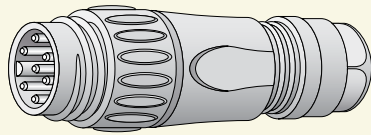

7 Pin Plug (Male)
Alarm output from Sensor

v) Attach sensor housing to the mounting pole.

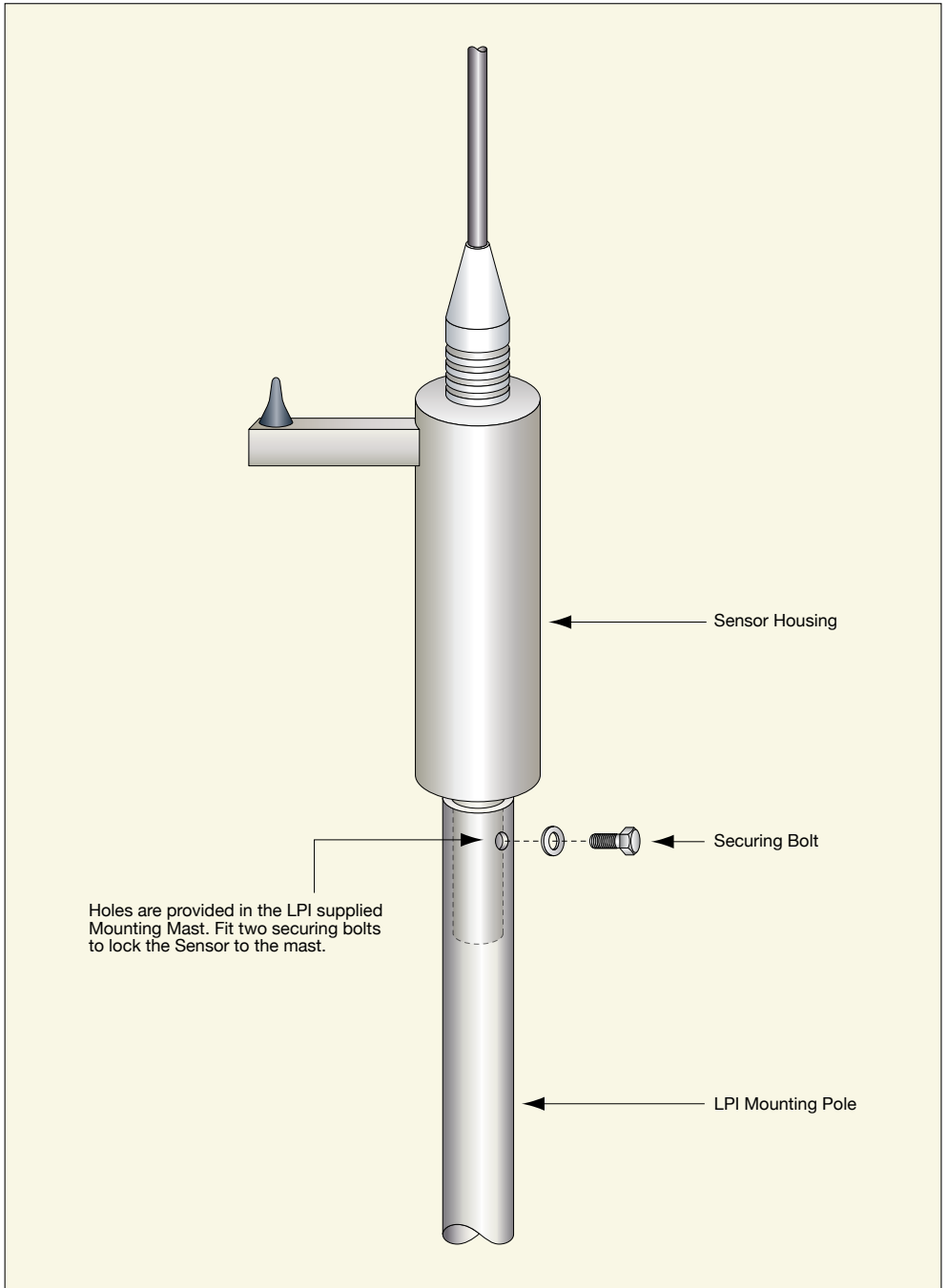

- vi) Securely place a mounting pole in the ground (recommended depth of at least 600mm with concrete and gravel fill).

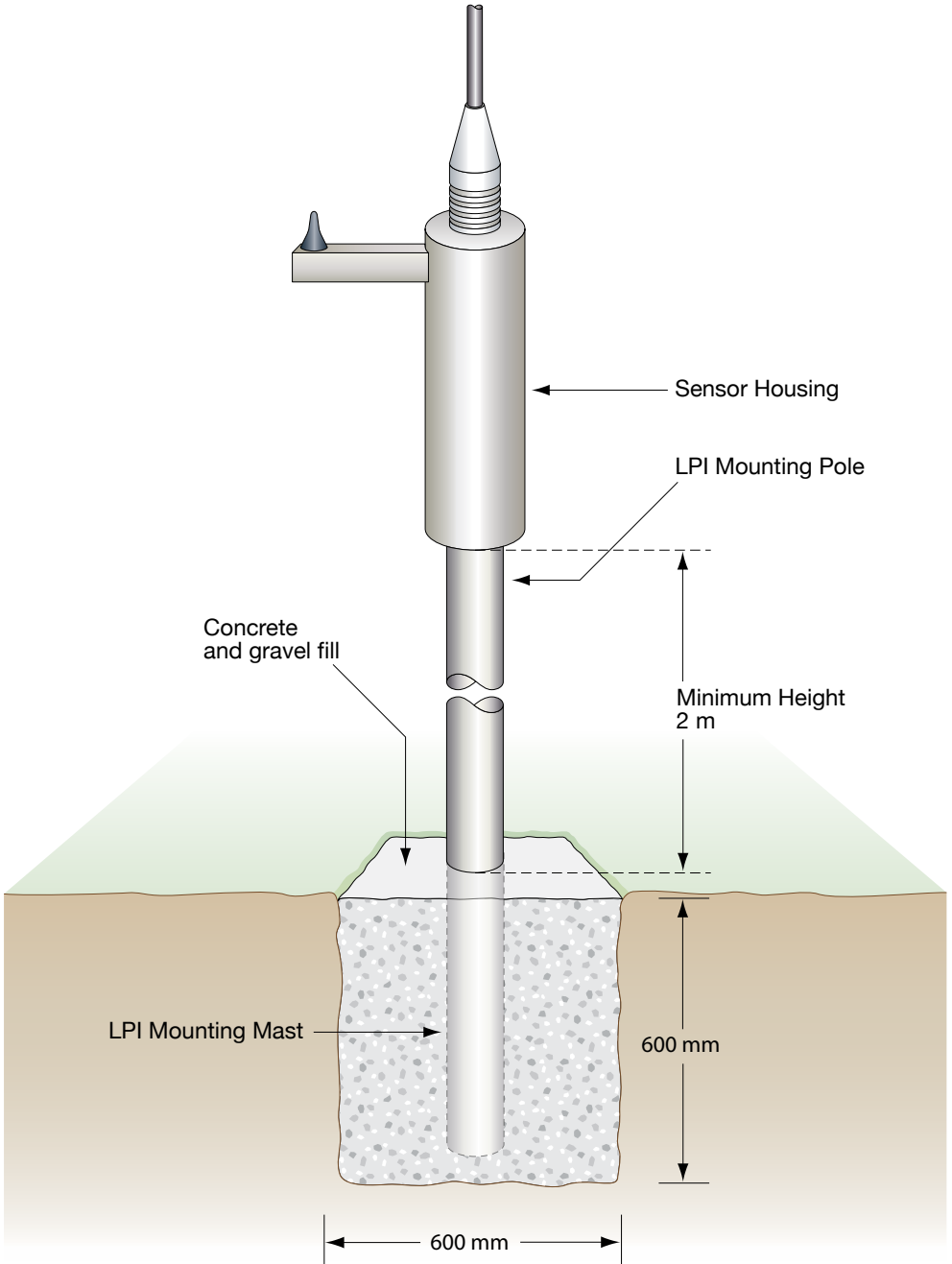

- vii) Drive the earth rod into the ground beside the Sensor Assembly and clamp the grounding cable (from the Sensor Assembly or from the 4 pin connector, see “Relay/Alarm Output and Power Connectors” section for details, page 44) to the rod using the rod clamp provided.

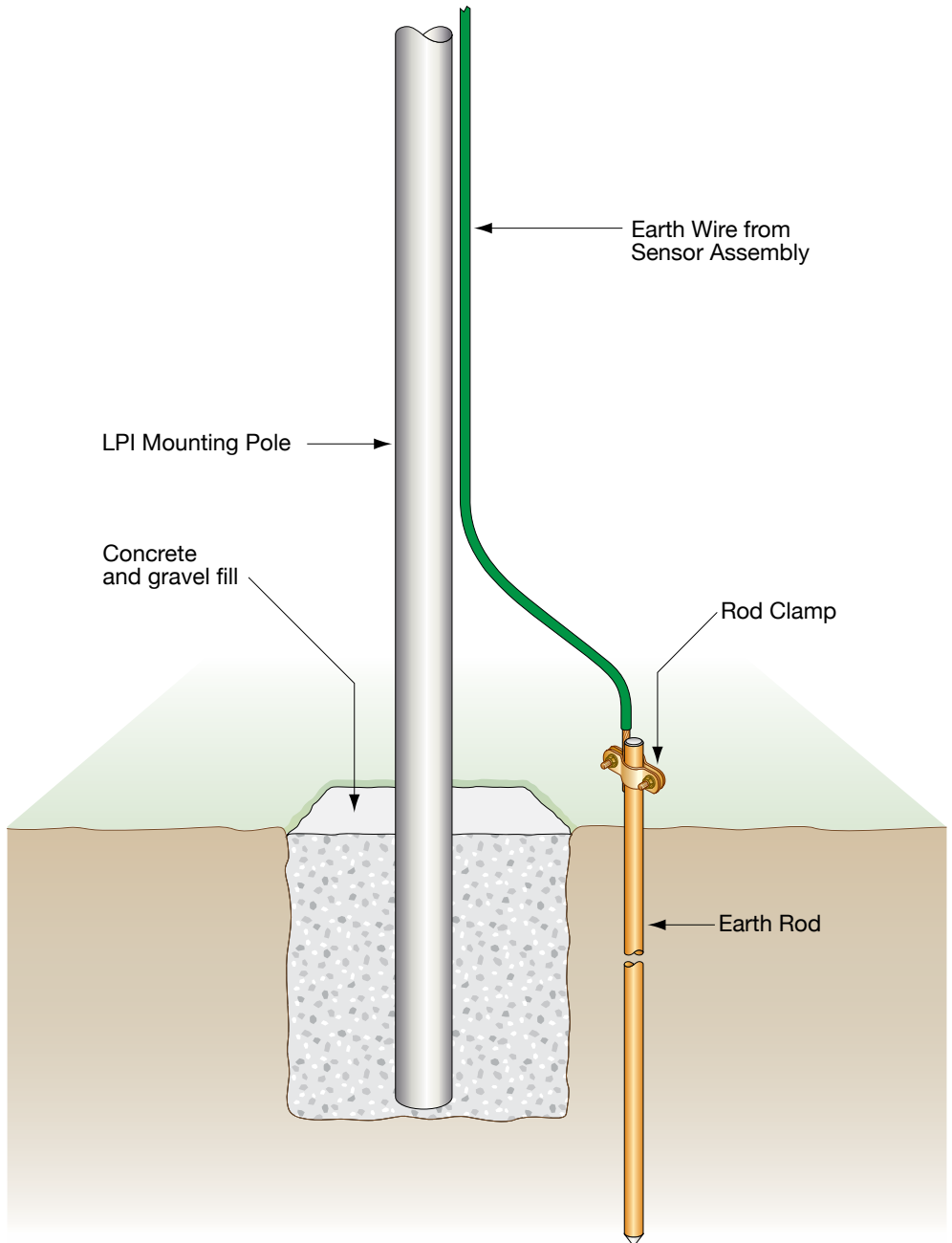

- viii) Ensure that the selected power supply and Alarm Indication device is connected correctly.
- ix) If supplied, mount the solar panel assembly (with battery) on the mounting pole. To achieve maximum battery charging, the solar panel should be aligned so that it faces towards the sun. For locations in the Southern hemisphere the panel should face North, in the Northern hemisphere the panel should face South. Ensure that the solar panel is not in the shadow of the mast at any time during the day.

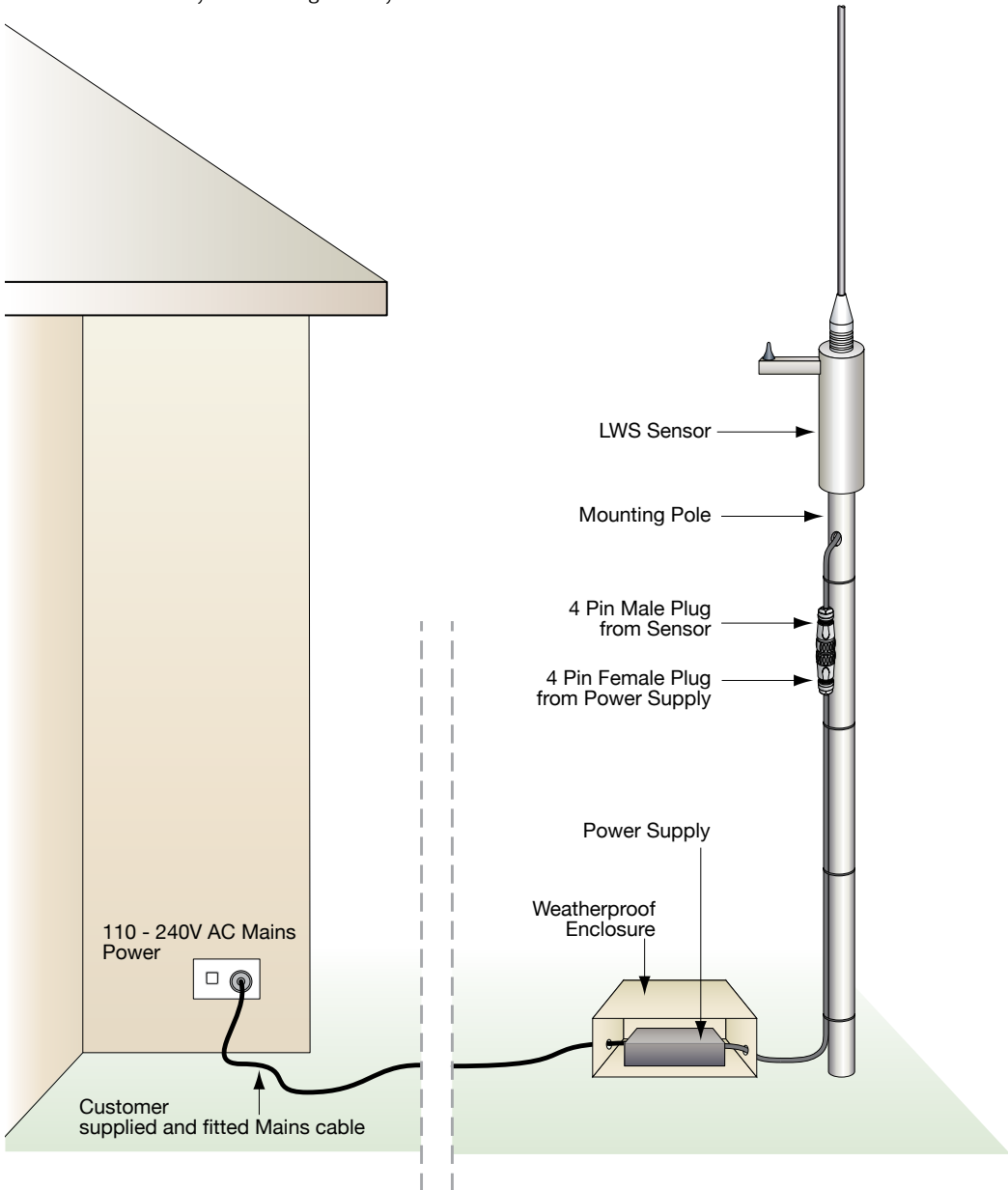

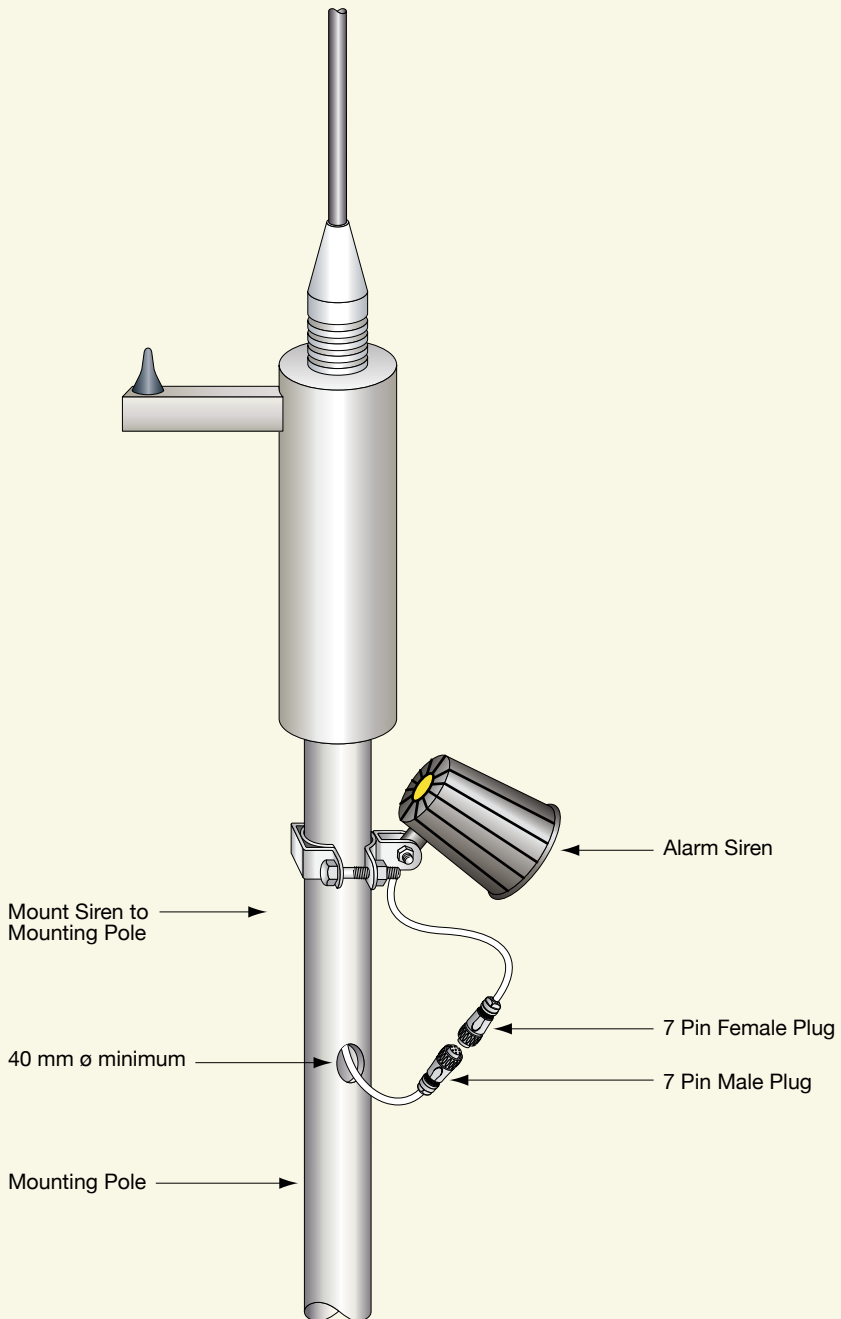

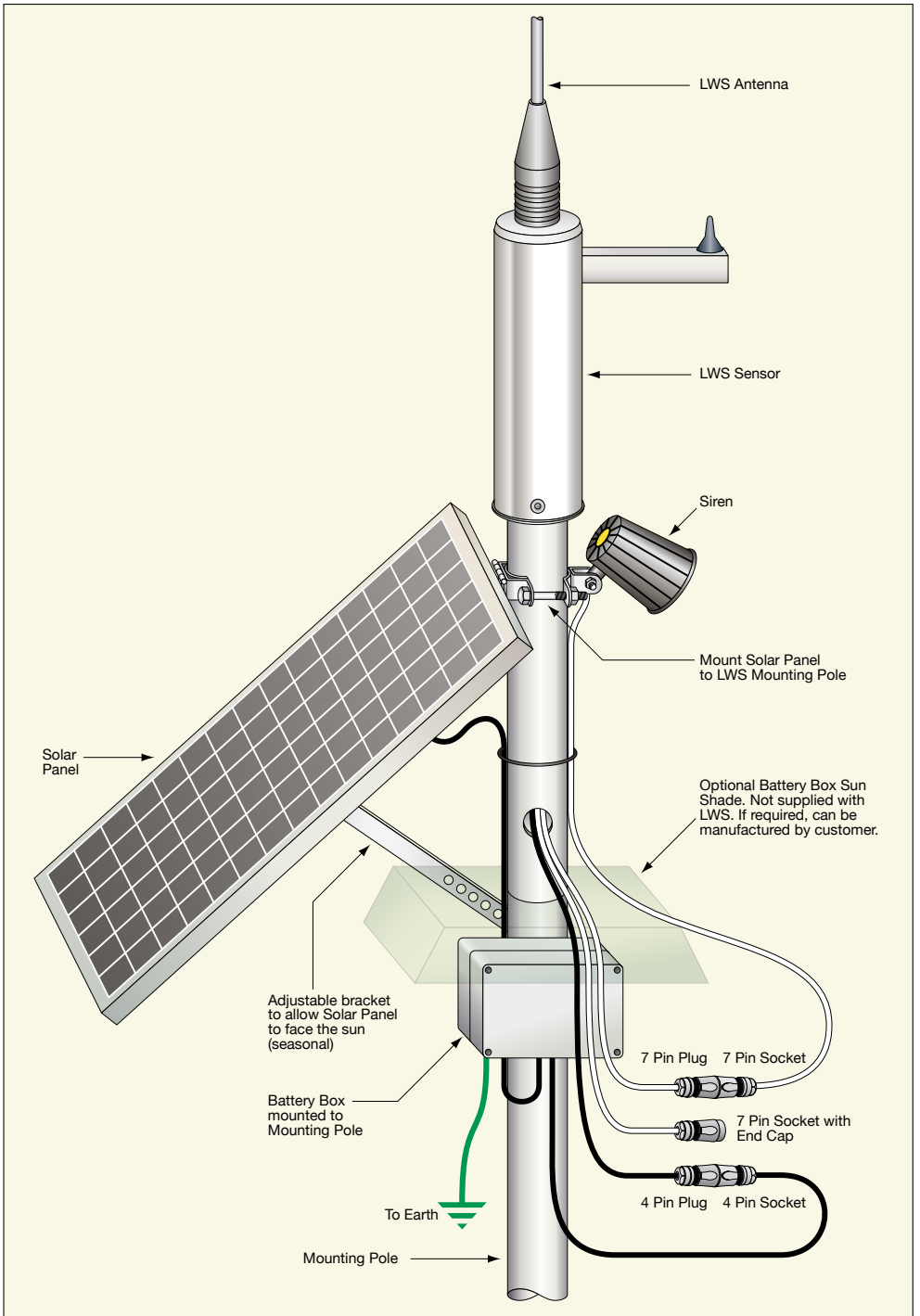

- x) The battery and circuitry in the power supply / battery box should be kept below 43 degrees Celsius at all times. Direct sun on a hot day will take the power supply box over this level. So if there is any possibility of this temperature being reached then shade must be provided for the power supply box. The shade must not restrict airflow around the box. See previous diagram.

For further advice on deployment in difficult conditions please contact LPI.

Once the Sensor Assembly has been configured and both the Alarm Indication device and power supply are connected, the sensor will run through a “Power-On-Self-Test”. This tests that the relay outputs are functioning correctly (an Alarm, Warning and All Clear Indication should be seen/heard briefly when alarm output is enabled). After approximately 30 seconds of operation without another “Power-On-Self-Test” the sensor is functioning correctly and ready for operation.

A mounting pole can be supplied by LPI as an optional extra if required. Any mounting pole supplied by the client must be 2-3m long to provide correct calibration height, and have a minimum internal diameter of 61.5mm.

Installation of Console / Console Antenna

The Console should be placed within approximately 2m of where the Console Antenna is to be mounted. The supplied cable length is 2.5m between the Console and the Console Antenna. The console should also be positioned within a suitable distance to a power point. An Ethernet Cable with a length of up to 50m can be used to connect the Console to a Network Switch or dedicated computer.

Once Console and Antenna have been installed in a suitable location, connect the Coaxial Antenna Cable to the Coaxial Flying Lead on the Console. The Console Antenna may be mounted inside building if close to a window and retains line of sight to nearest sensor or Range Extender.

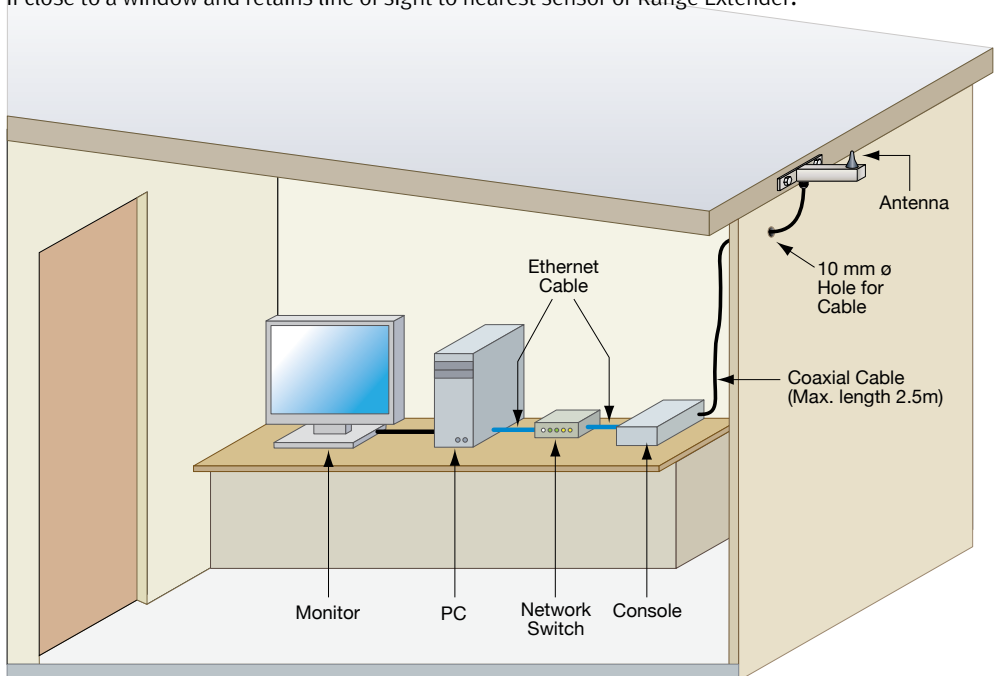

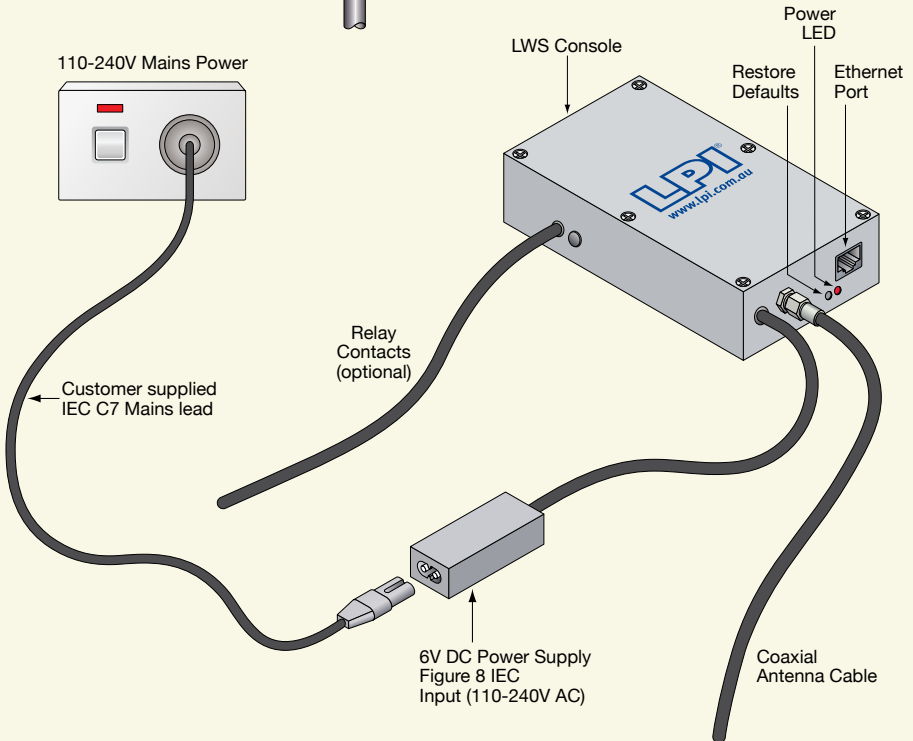
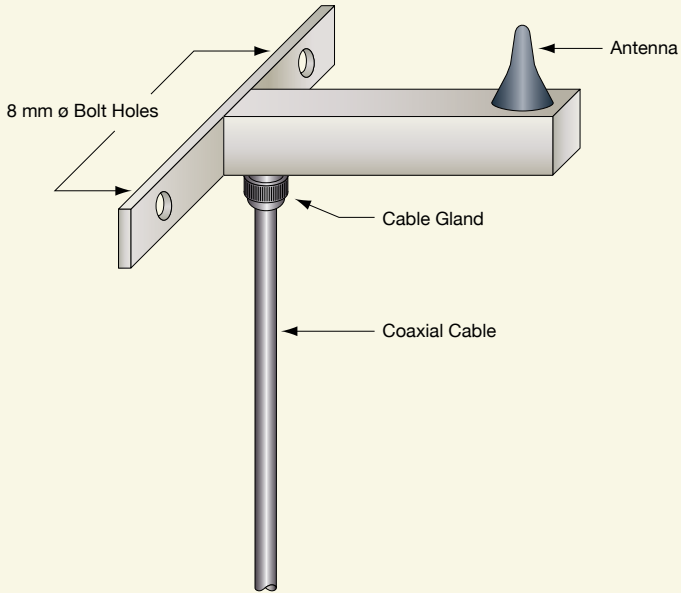

Approved Sensor Locations

To ensure correct operation of the LPI LWS MkIII, the following requirements for possible Sensor locations must be adhered to:

- i) For single Sensor systems the Sensor Assembly location must be within 1km of the Console antenna with direct line of sight between the two wireless antennas.
- ii) Sensor Assemblies must be located on “flat” (some elevation is acceptable) ground. Installing the Sensor on raised ground or on any structure or building will increase the electrostatic intensification at the tip of the Sensor antenna, therefore giving false e-field readings and alarms.
- iii) A minimum distance of 7m between the Sensor Assembly and any nearby structure or trees. Tall objects close to the Sensor will have a shielding effect on the measured e-field at the tip of the Sensor antenna, therefore giving false e-field readings.

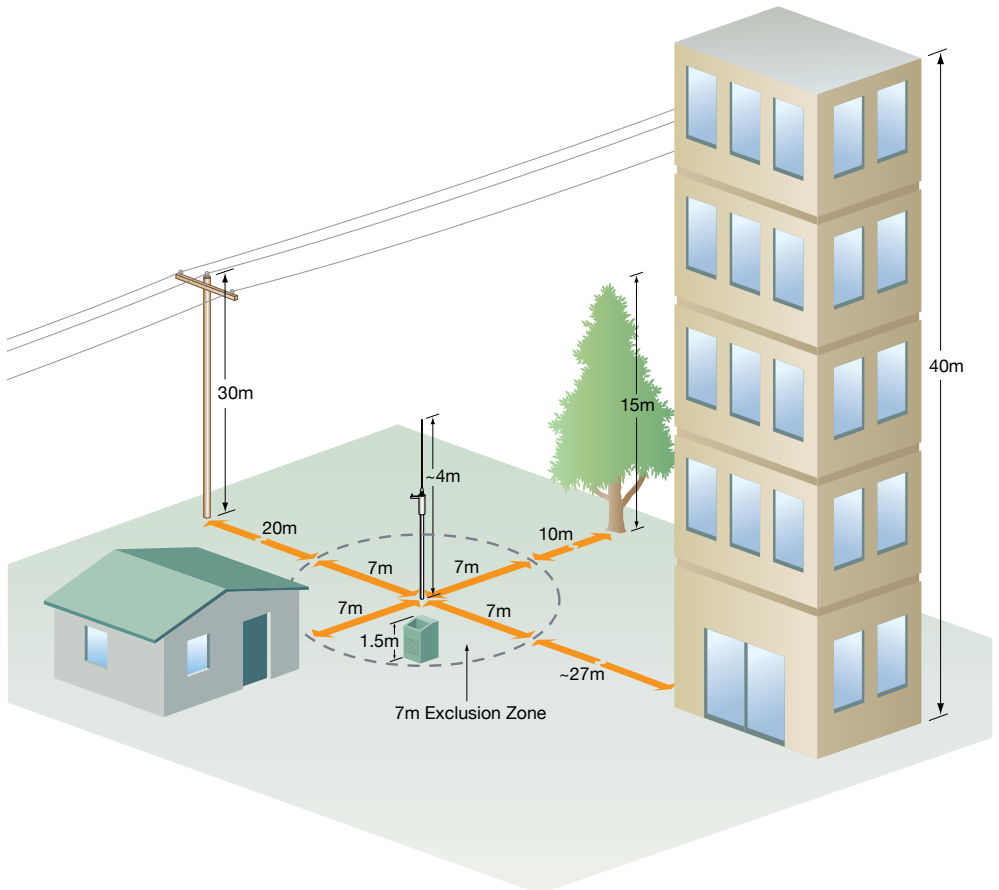

- iv) The Sensor Assembly should not be placed under or within 7m of power or telephone wires.
- v) Height of objects within 7m of the sensor should be at most 1.5m tall.
- vi) Minimum 7m distance applies to objects with a height comparable to the sensor, taller objects will need to be further away to prevent shielding of the sensor. Recommended distance is $\frac{2}{3}$ the height of the object in addition to the 7m separation.

The Sensor should only be installed in locations conforming to the “Approved Sensor Locations” requirements.

Range Extender Installation

As Range Extenders do not have any lightning event detection capability they are not subject to the same location restrictions as Sensors. Range Extenders will need to be placed in positions that allow <1km line of sight to the Console, Sensor or another Range Extender.

Cabling installation, Alarm relay plug and socket, mounting, power supply, siren and solar panel installation instructions are as shown in Sensor Installation points iii (without sensing antenna or earthing cable), iv, v, viii and ix respectively.



Accessing the Interface homepage

To start using the LWS Connect the console to power. Connect the out-door wireless antenna, to the console by screwing the antenna cable in. Connect the provided cross-over Ethernet cable to the LWS and to your computer.

Ensure that your computer has an IP Address of 192.168.1.1 (or similar) and a subnet mask of 255.255.255.0. If you need further information please refer to section “Establishing a LAN Connection to the LWS Console”

Open an approved web browser (Microsoft Internet Explorer, Mozilla Firefox or Google Chrome) and type into the address box, the address 192.168.1.90. Once the Home page is accessed the IP of the console can be changed in the “IP address” button, this can be found by clicking on the “Settings” link.

To reset the Console default IP Address settings, see the section entitled “Restoring Console Factory Default Values”.

The Home page provides the basic system information to the user. It shows:

- The current Electric-Field being measured in the form of Graphs (0-10kV/m).
- The current Lightning Warning System Time and Date (see “Changing the Settings: Time and Date” for more information). If the colour of the time is red then your PC time is different to your LWS time. If the times are different they should be changed to the correct local time.
- The status of the Sensor and Range Extender batteries (if connected and only if it is flat).
- If a Lightning event has been detected.
- A series of links to other sections of the web user interface.
- Current Alarm State (All Clear, Warning or Alarm)

Home - Mozilla Firefox

File Edit View History Bookmarks Tools Help

Home

192.168.116.86/INDEX.HTM

Google

LPI Lightning Warning System

LWS

Links

- [Home](#)
- [Event Log](#)
- [Settings](#)
- [Supporting Documents](#)

Lightning Warning System Time

11:22:56 AM
Friday, 30 March 2012

ALL CLEAR

Console 2.4
Release date Mar 9 2012

- [English](#)
- [简体中文](#)
- [繁體中文](#)

Event Indication

No Event Detected

Electric Field Level

10kV/m
9kV/m
8kV/m
7kV/m
6kV/m
5kV/m
4kV/m
3kV/m
2kV/m
1kV/m

LIGHTNING PROTECTION INTERNATIONAL PTY LTD

LPI AUSTRALIA

Event Log

By clicking on the “Event Log” the user will be directed to a page displaying the log of previous events. A maximum of 150 different events will be stored in the Log (above this number new events will overwrite old events).

Log entries are broken into three parts:

- the type of event,
- the unit which recorded the event, this is MA for Master and RE for a range extender,
- the time and date at which the event was recorded.

The screenshot shows a web browser window titled "Event Log - Mozilla Firefox". The address bar contains "lws/LOG.HTM". The page header features the "LPI Lightning Warning System" logo. Below the logo, there are two buttons: "Erase Event Log" and "Save Event Log". The main content area is titled "Event Log" and contains a table of event entries. On the left side, there is a sidebar with "LWS" and "Links" including "Home", "Event Log", "Settings", and "Supporting Documents". At the bottom left, there are language options: "English", "繁體中文", and "繁體中文". At the bottom center, it says "LIGHTNING PROTECTION INTERNATIONAL PTY LTD" and at the bottom right, there is a logo for "LPI AUSTRALIA".

Event Type	Unit	Date	Time
Found	MA	Mar 26	23:09:40 2012
Lost Comm	MA	Mar 26	23:09:05 2012
E Field Low	Mar 26	23:07:55 2012	
E Field Low	Mar 26	22:57:41 2012	
E Field Low	Mar 26	22:46:29 2012	
E Field Low	Mar 26	22:34:20 2012	
Found	MA	Mar 26	09:41:02 2012
E Field Low	Mar 26	00:06:51 2012	
Found	MA	Mar 26	00:06:44 2012
Lost Comm	MA	Mar 26	00:06:32 2012
E Field Low	Mar 26	00:03:04 2012	
E Field Low	Mar 26	00:01:01 2012	
E Field Low	Mar 25	23:59:00 2012	
E Field Low	Mar 25	23:57:41 2012	
E Field Low	Mar 25	23:52:57 2012	
E Field Low	Mar 25	23:50:54 2012	
E Field Low	Mar 25	23:39:43 2012	
Found	MA	Mar 25	09:06:40 2012
Lost Comm	MA	Mar 25	00:03:49 2012
E Field Low	Mar 25	00:01:27 2012	
E Field Low	Mar 24	23:23:50 2012	
Found	MA	Mar 24	09:04:52 2012
Lost Comm	MA	Mar 23	22:48:57 2012
E Field Low	Mar 23	22:46:33 2012	
E Field Low	Mar 23	21:33:20 2012	
All Clear	Mar 23	15:43:09 2012	
E Field Low	Mar 23	15:30:42 2012	
E Field High	Mar 23	15:26:59 2012	
E Field High	Mar 23	15:25:43 2012	
E Field High	Mar 23	15:24:17 2012	
E Field High	Mar 23	15:23:24 2012	

There are several different event types which may be seen in the Log window. Types include:

- Far Strike, the sensor recorded a far strike.
- Near Strike, the sensor recorded a near strike.
- E Field High, the sensor recorded a high electric field.
- E Field Low, the sensor recorded a low electric field.

- All Clear, the event timer on the sensor timed-out and there is now no lightning activity within the detection range.
- Found MA, the sensor regained communications with the console after a communication time-out.
- Lost MA, the console has lost communications with the Master Sensor.
- Reset MA, the sensor experienced a power or timer reset.
- Low Batt *, the corresponding sensor or Range Extender has a low battery.
- Low RSSI *, the corresponding sensor or Range Extender has a low wireless signal strength.

The Log page also has option buttons Erase the event log (this should only be done if the current event log is no longer required, data cannot be reinstated) and to save the currently displayed event log as a text file.

Saving the current displayed event log as a text file works differently in both Internet Explorer and Firefox.

Saving in Internet Explorer:

By pressing the “Save Event Log” button in IE, the user will be directed to a page displaying the text file. To save the file go to the “page” menu, then click “save as” and save as a text file in the desired location on the connected computer.

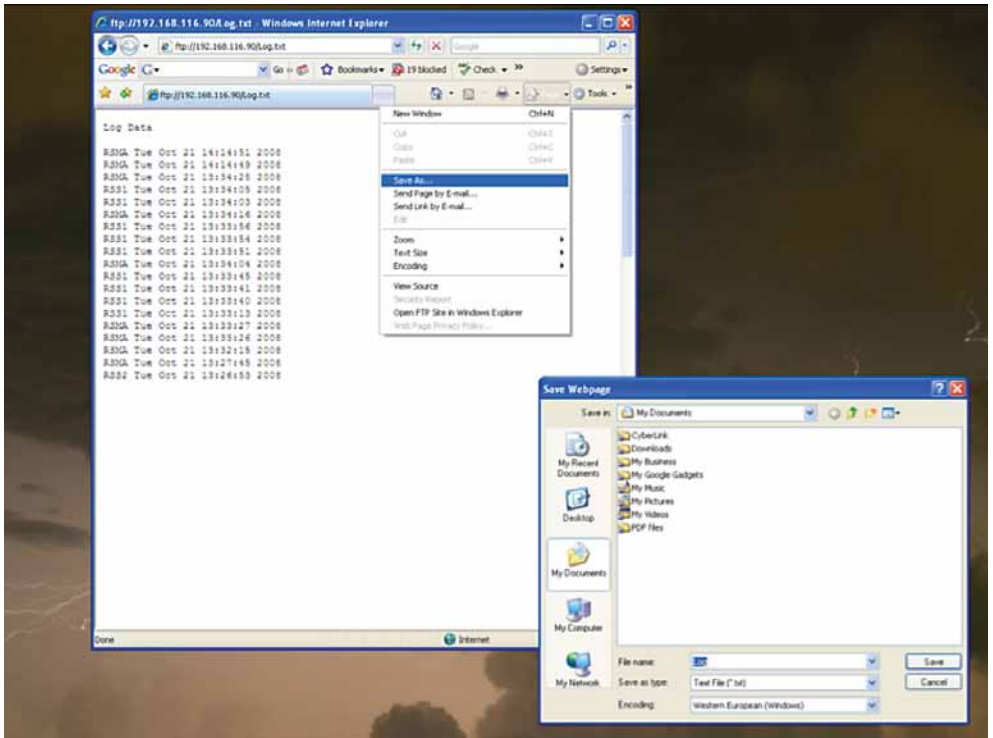

Note: earlier versions will be similar to Firefox method on the following page.

Saving in Firefox:

By pressing the “Save Event Log” button in Firefox, the user will be taken to a page displaying the file. To save the file click on the “file” menu and then click “save page as”. The log text file can then be saved in the desired location on the connected computer.

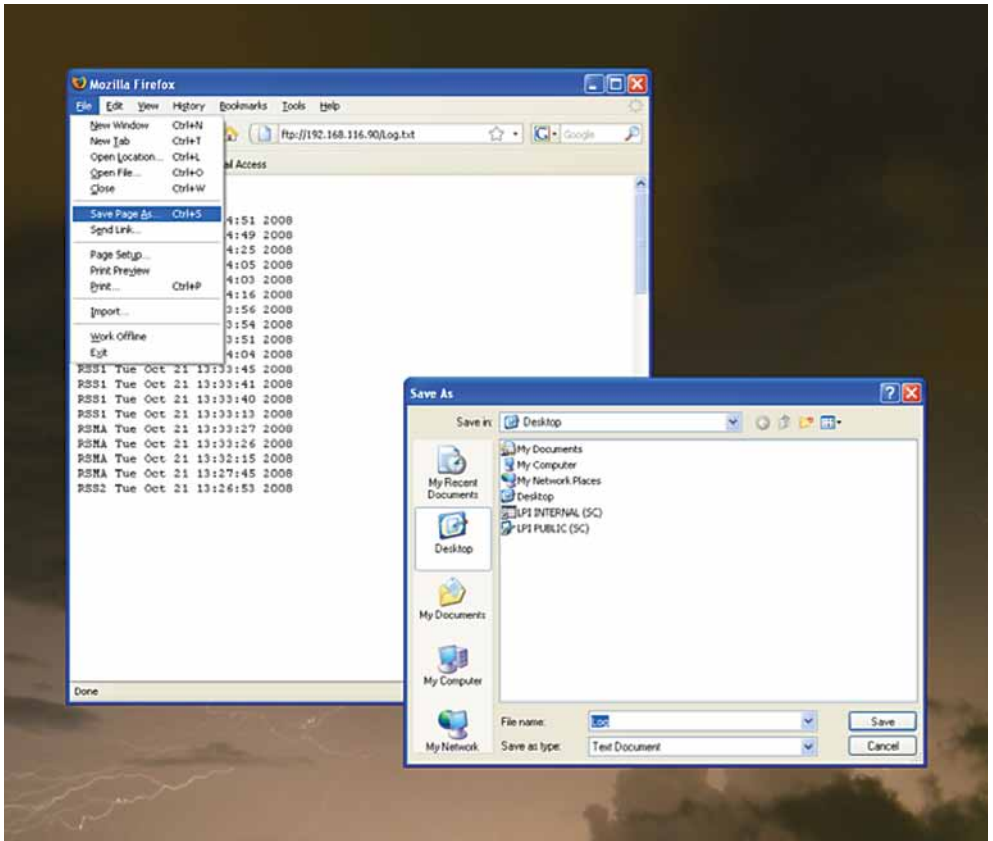

Saving in Google Chrome

By pressing the “Save Event Log” button in Google Chrome. The user will be directed to a page displaying the file. To save the file click on the “page” icon in the top right corner of the Google Chrome browser and then click on “save page as”. The log text file can then be saved in the desired location on the connected computer.

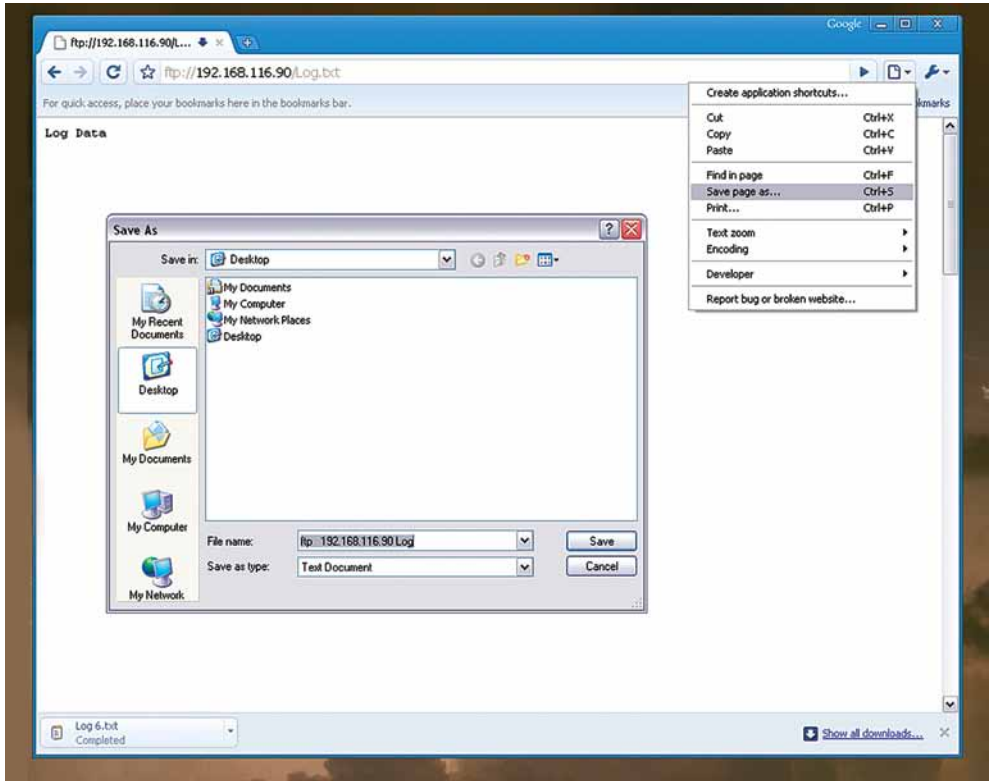

Changing the Settings

To access most of the setting pages a username and password is required each time a new browser session is started (browser closed then opened again). The default username and password is “admin” and “admin” respectively. The username and password can be changed in the Username/Password page.

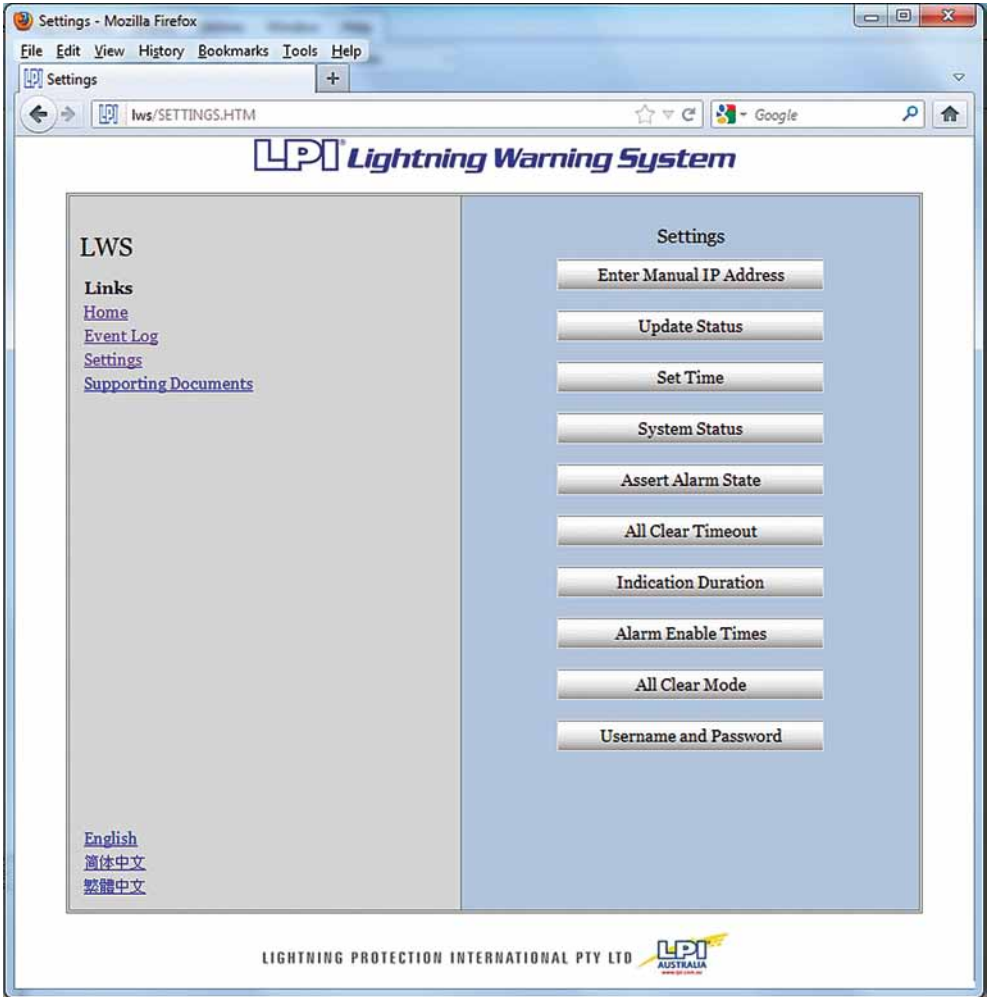

Settings: IP Address

This page allows the user to change the IP Address, IP Mask, Gateway Address and DNS Address of the console. The Address settings of the console can either be set by manually choosing preferred values or by setting the console to automatically download Addresses from a local connected DHCP server. When manually setting the Address if the IP Mask, Gateway Address and DNS Address remain unchanged from a previous setup, then these fields may be left blank.

Note: Addresses assigned automatically by a DHCP server may change without warning if the console or network router is restarted.

Refer to sections “Establishing a LAN Connection to the LWS Console” and “How to put LWS onto a Network” for step-by-step guide on how to set-up the LWS Console so it can be accessed on your Local Area Network.

LPI[®] Lightning Warning System

<p>LWS</p> <p>Links Home Event Log Settings Supporting Documents</p> <p>Current IP Address: 192.168.116.86 Current IP Mask: 255.255.255.0 Current Gateway Address: 192.168.116.254 Current DNS Address: 192.168.116.1</p> <p>Warning by changing the IP Address you may be unable to view the LWS web pages. Please ensure that the correct IP Address is set</p> <p>English 简体中文 繁體中文</p>	<p style="text-align: center;">Set IP address Manual or Automatic</p> <p style="text-align: center;">Enter Manual IP Address: <input type="text"/></p> <p style="text-align: center;">Enter Manual IP Mask (typically 255.255.255.0): <input type="text"/></p> <p style="text-align: center;">Enter Manual Gateway Address: <input type="text"/></p> <p style="text-align: center;">Enter Manual DNS Address: <input type="text"/></p> <p style="text-align: center;"><input type="button" value="Set"/></p> <p style="text-align: center;">Automatically get IP Addresses from a connected DHCP server <input type="button" value="Automatic"/></p>
---	---

Settings: Update Status

This page allows the user to check on the status and voltage of connected batteries. If Range Extenders have been included in the system, a “battery flat” warning is displayed on this page when the Range Extender battery is flat. This page is a display page only, no settings can be changed on this page.

LPI[®] Lightning Warning System

LWS

Links

[Home](#)

[Event Log](#)

[Settings](#)

[Supporting Documents](#)

[English](#)

[简体中文](#)

[繁體中文](#)

Console Receive Signal Strength is: -50dB

Sensor Receive Signal Strength is: -64dB

Update

LIGHTNING PROTECTION INTERNATIONAL PTY LTD



Settings: System Time

It is very important that the LWS time is set accurately to the local time.

This page allows the user to update the System Time of the LWS. Having a correct system time is important for correlating observed lightning events with those recorded in the event log, and that the alarms are enabled at the correct times.

There are two time and dates displayed on this page, one is from the computer connected to the console (which is assumed to have the correct time) and the second is the current LWS time and date. If these two time and dates are found to be different, then the system time can be set to the correct time. A time difference of up to a minute is not a problem.

The “Refresh” button will preload the input boxes with the PC’s current local time. Pressing the “Set” button will set the LWS time to the time loaded in the text boxes. This time will be sent to all elements of the system.

LPI[®] Lightning Warning System

LWS Links Home Event Log Settings Supporting Documents English 简体中文 繁體中文	Lightning Warning System Time Thursday, 5 April 2012 11:32:43 AM PC Time Thursday, 5 April 2012 11:32:47 AM Set Time Year <input type="text" value="2012"/> Month <input type="text" value="4"/> Day <input type="text" value="5"/> Hours <input type="text" value="11"/> Minutes <input type="text" value="32"/> Seconds <input type="text" value="48"/> <input type="button" value="Refresh"/> <input type="button" value="Set"/>
--	--

Settings: System Status

This page is similar to the main page but has the addition of a Status Table.

The Status Table lists all the LWS Entities that are currently connected or have been connected to the radio network. An entity can be either the Console or the Sensor or one of the range extenders (if used). Each entity gives its Name, Voltage, Signal Strength and its communications status.

Sometimes some of the readings will be Red or Orange in colour, if these colours persist it indicates a possible problem. If a voltage or signal strength reading goes red occasionally but comes back green it is not a problem, just a missed packet. At startup the readings will all be Red for the first couple of minutes. Don't worry about this.

Generally the voltage should be above 11.3 volts, except for the console, which should be 6 volts. Generally the signal strengths should be between -35db and -85db. The closer the signal strength is to zero the stronger it is.

LPI[®] Lightning Warning System

LWS

Links
[Home](#)
[Event Log](#)
[Settings](#)
[Supporting Documents](#)

Lightning Warning System Time
3:43:31 PM
Friday, 30 March 2012

ALL CLEAR

Entity	Voltage (volts)	Signal (dbm)	Comms
Console	6.0	-62	OK
Sensor	13.75	-63	OK

Console 2.4
Release date Mar 9 2012

[English](#)
[简体中文](#)
[繁體中文](#)

Event Indication

No Event Detected

Electric Field Level

10kV/m
9kV/m
8kV/m
7kV/m
6kV/m
5kV/m
4kV/m
3kV/m
2kV/m
1kV/m

Settings: Alarm Reassert

This page allows the user to reassert current alarm conditions by manually sounding the siren. It can also be used to test the sirens.

If the LWS is in Warning or Alarm condition, then the user cannot assert an All Clear or a lower level condition. If this is the case the button will not be visible to do this. The reason for this is for safety.

To test the Siren outputs the User will have to wait for the All Clear condition first.

LPI Lightning Warning System

LWS Links Home Event Log Settings Supporting Documents English 简体中文 繁體中文	Assert Alarm State <input type="button" value="Alarm On"/> <input type="button" value="Warning On"/> <input type="button" value="All Clear"/>
--	---

LIGHTNING PROTECTION INTERNATIONAL PTY LTD



Settings: All Clear Time-out

This page allows the user to change the length of time between the last recorded lightning event (Near/Far Strike, High/Low E-Field) and the All Clear Indication. The user has the option of choosing a time between 10 minutes and 30 minutes before the All Clear Indication is enabled. After the settings have been updated if the Current All Clear Time-out Period does not show the time which had just been set, refresh the webpage. If the Time-out Period is still incorrect select the required time from the drop down list again and allow system to update the settings.

The default All Clear Time-out is 15minutes.

LPI Lightning Warning System

LWS Links Home Event Log Settings Supporting Documents English 简体中文 繁體中文	Current All Clear Timeout period is 15 Minutes <table border="1"><tr><td>15</td><td><input type="button" value="Set"/></td></tr><tr><td>10</td><td></td></tr><tr><td>12</td><td></td></tr><tr><td>15</td><td></td></tr><tr><td>20</td><td></td></tr><tr><td>25</td><td></td></tr><tr><td>30</td><td></td></tr></table>	15	<input type="button" value="Set"/>	10		12		15		20		25		30	
15	<input type="button" value="Set"/>														
10															
12															
15															
20															
25															
30															

LIGHTNING PROTECTION INTERNATIONAL PTY LTD



Settings: Indication Duration

This page allows the user to change the length of time for Alarm, Warning and All Clear Indications to occur for. The user has the option of choosing a time (between 5 seconds and 60 seconds) to have indications enabled for. After the settings have been updated, the Current Indication Duration should show the time which had just been set, if not then refresh the webpage. If the Duration is still incorrect select the required time from the drop down list again and allow system to update the settings.

The default Indication Duration is 10 Seconds.

LPI[®] Lightning Warning System

LWS

Links

- [Home](#)
- [Event Log](#)
- [Settings](#)
- [Supporting Documents](#)

[English](#)
[简体中文](#)
[繁體中文](#)

Current Indication Duration is 10 Seconds

10

- 5
- 7
- 10
- 15
- 20
- 25
- 30
- 45
- 60

Settings: Alarm Enable Times

This page allows the user to change the time at which Alarm (Warning and All Clear) Indications are enabled and disabled, so that if lightning events occur during a time when the area is not in use there will be no unnecessary alarms. Both on and off times are set by simply inputting the required times and pressing the set button.

Note: All times should be entered in 24 hour format to ensure correct operation. The system will not process an AM or PM time correctly. The on time must be before the off time.

Please note that it is very important to set the Alarm Enable Times correctly.

LPI[®] Lightning Warning System

<p>LWS</p> <p>Links</p> <p>Home</p> <p>Event Log</p> <p>Settings</p> <p>Supporting Documents</p> <p>Current On Time : 07:30:00</p> <p>Current Off Time : 18:30:00</p> <p>English</p> <p>简体中文</p> <p>繁體中文</p>	<p>On Time</p> <p>Hours: <input type="text"/></p> <p>Minutes: <input type="text"/></p> <p>Seconds: <input type="text"/></p> <p>Off Time</p> <p>Hours: <input type="text"/></p> <p>Minutes: <input type="text"/></p> <p>Seconds: <input type="text"/></p> <p style="text-align: center;"><input type="button" value="Set"/></p>
--	---

LIGHTNING PROTECTION INTERNATIONAL PTY LTD



Changing the Settings: All Clear Mode

Sometimes an LWS is in Alarm condition at the time the alarms are disabled. (By the Alarm Enable Times). This means that an Alarm has sounded but no corresponding All Clear has been given. When this is the case there are three options here to do with how to sound the All Clear.

You must choose one option.

- All Clear Force: sound the All Clear at the time the Alarms are disabled, this will mean an All Clear is given even though the LWS is not in all clear.
- All Clear Allow: sound the All Clear at the Normal time even though this will be when the Alarms are disabled.
- All Clear Normal: don't sound the All Clear for this alarm, because it would be outside the Alarm Enable times.

LPI[®] Lightning Warning System

LWS

Links

- [Home](#)
- [Event Log](#)
- [Settings](#)
- [Supporting Documents](#)

[English](#)
[简体中文](#)
[繁體中文](#)

All Clear Mode

The diagram illustrates the timing of All Clear modes relative to alarm events. A lightning bolt icon marks the start at 'Near or High Efield'. Three horizontal bars represent the modes: 'FORCE MODE' (grey), 'NORMAL MODE' (yellow), and 'ALLOW MODE' (grey). Vertical dashed lines indicate 'Alarm Disable Time' and 'All Clear Time-out'. A siren icon with a red 'X' indicates that 'NORMAL ALL CLEAR' would not sound. A siren icon indicates that 'ALLOW ALL CLEAR' sounds after the alarm is disabled.

Current All Clear Mode is: Force Mode

Changing the Settings: Username and Password

This page allows the user to set the username and password for accessing the individual settings pages. The username and password can be set to any string of characters, 10 characters or less. Both the username and password are case sensitive. Once a new username and password has been entered the user will be required to enter these before being able to access any settings pages.

If the Console is restored to factory defaults or no specific username and password have yet been set, the username and password will be “admin” and “admin” respectively.



Restoring Console Factory Default Values

Before restoring the LWS to factory default settings you should try to ensure that the LWS console, the Sensor and all the range extenders are communicating.

To restore the LWS to factory default values, use a paper clip or similar object to press the factory default reset button.

When the button is pressed the red “Power On” led will initially turn off. Keep the button pressed until the led starts flashing, this will take 3 seconds. The LWS will now reboot with the default settings.

If the button is released before the Power On LED starts flashing the LWS will do nothing.

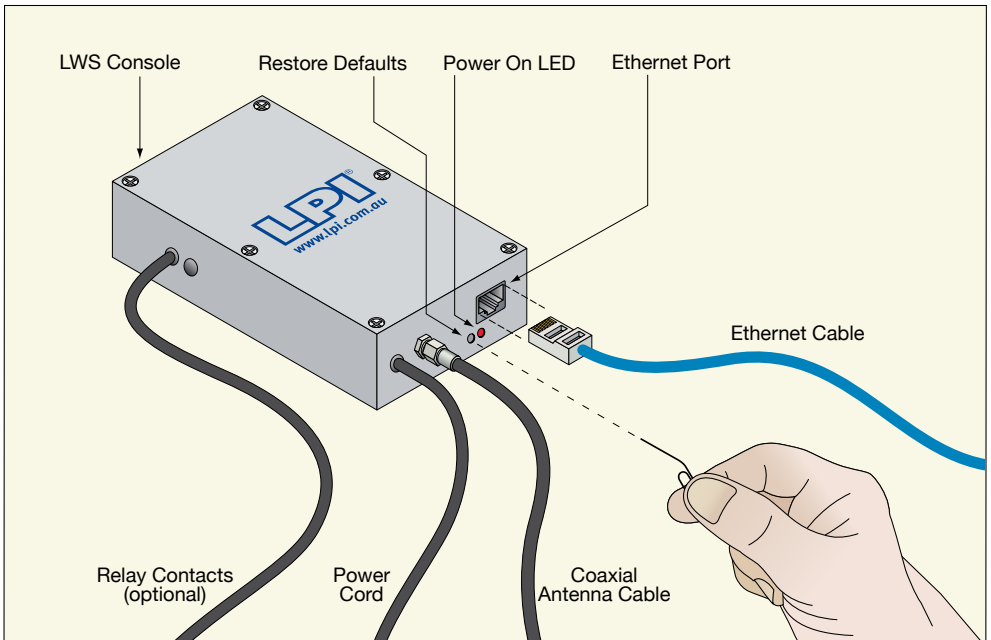

After automatically restarting, the Console will have regained the following default values:

- Alarm Duration: 10secs.
- All Clear Timeout Period: 15mins
- All Clear Mode: Normal
- Console IP Address: 192.168.1.90
- Console IP Mask: 255.255.255.0
- Gateway Address: 0.0.0.0
- DNS Address: 0.0.0.0
- Alarm Enable On Time : 07:30:00
- Alarm Enable Off Time : 18:30:00
- Username : admin
- Password : admin

Note: After restoring the factory defaults, the Console IP Address settings will need to be changed to allow connectivity to a connected computer, or via a local network. Also please set all values manually to your required settings.

Establishing a LAN Connection to the LWS Console

Introduction

To communicate with the LWS you also need a personal computer, tablet or smartphone.

Communication needs to be established between your device and the LWS, at least partially through a wired LAN (local area network).

It is also possible to establish communication through a hybrid wired/wireless LAN too.

There are three basic ways to set up the networking between the LWS console and a host computer.

1. A peer to peer network with Static IP addresses. Use crossover Ethernet Cable(Normally red or black).
2. With the LWS as a static IP Address on a larger existing LAN. Use Straight Through Ethernet Cable (normally blue).
3. With the LWS as a dynamic IP Address on a larger existing LAN. Use Straight Through Ethernet Cable(Normally blue).

If you have an existing wired LAN and you wish to add the LWS to it you will have to work in co-operation with your network administrator.

You can contact LPI and they can email you a windows program to make it easy to set up the LWS on your network.

Alternatively you can initially set up the communications as a peer to peer network, and then change the configuration once communication is established.

Setting up a direct connection network for the LWS using Windows 7

All networked computers have what is known as an IP Address.

The LWS console has as a default address out of the factory, which is 192.168.1.90

The LWS console has as a default address mask out of the factory, which is 255.255.255.0

To set up a direct connection network you need to set up your PC to have a static IP Address of 192.168.1.1 and an Address Mask 255.255.255.0.

These settings will enable communication.

Step 1.

Start Windows Explorer (not Internet Explorer)

This can be done in many ways, here is one:

- Click on the Start button at the bottom left of the screen.
- Directly above the start button is a text box, type in the word “explorer”
- At the top should be a link to “Windows Explorer”, click on it.

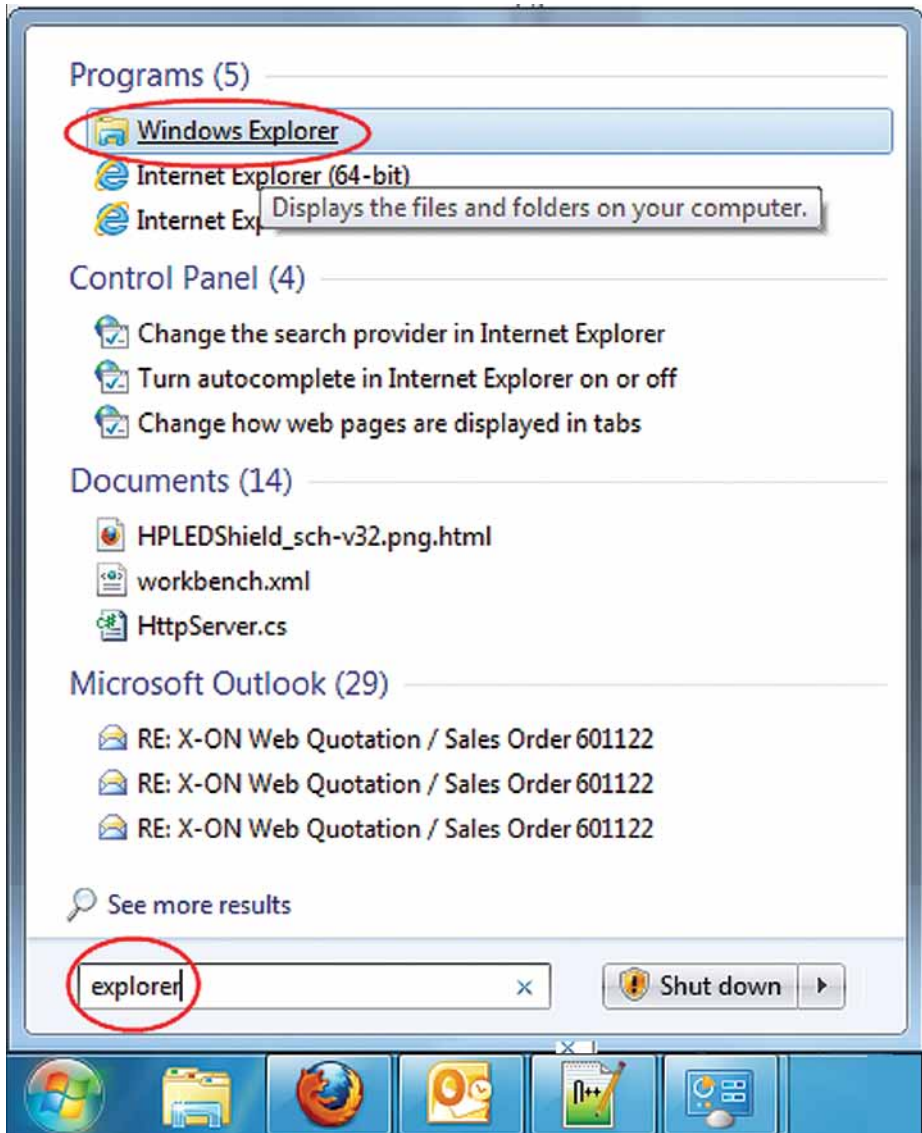

Step 2.

Open the Networking And Sharing Center

This can be done in many ways, here is one:

- Type in the path in the diagram.
- Press the “Enter” key.



Step 3.

Click on the link marked “Local Area Connection”

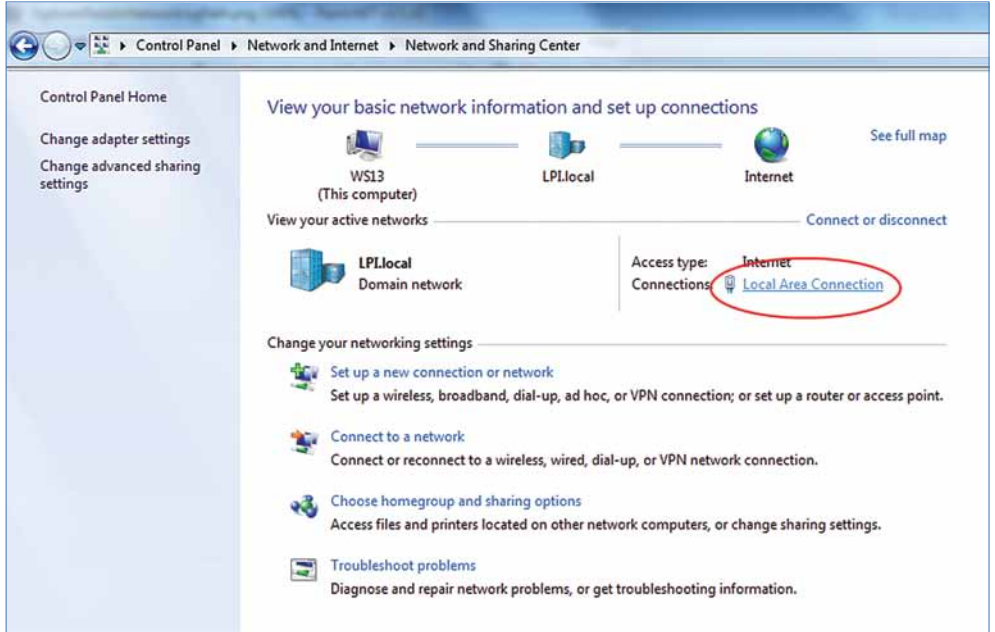

Step 4.

In the page name Local Area Connection Status, Click on the button marked “Properties”

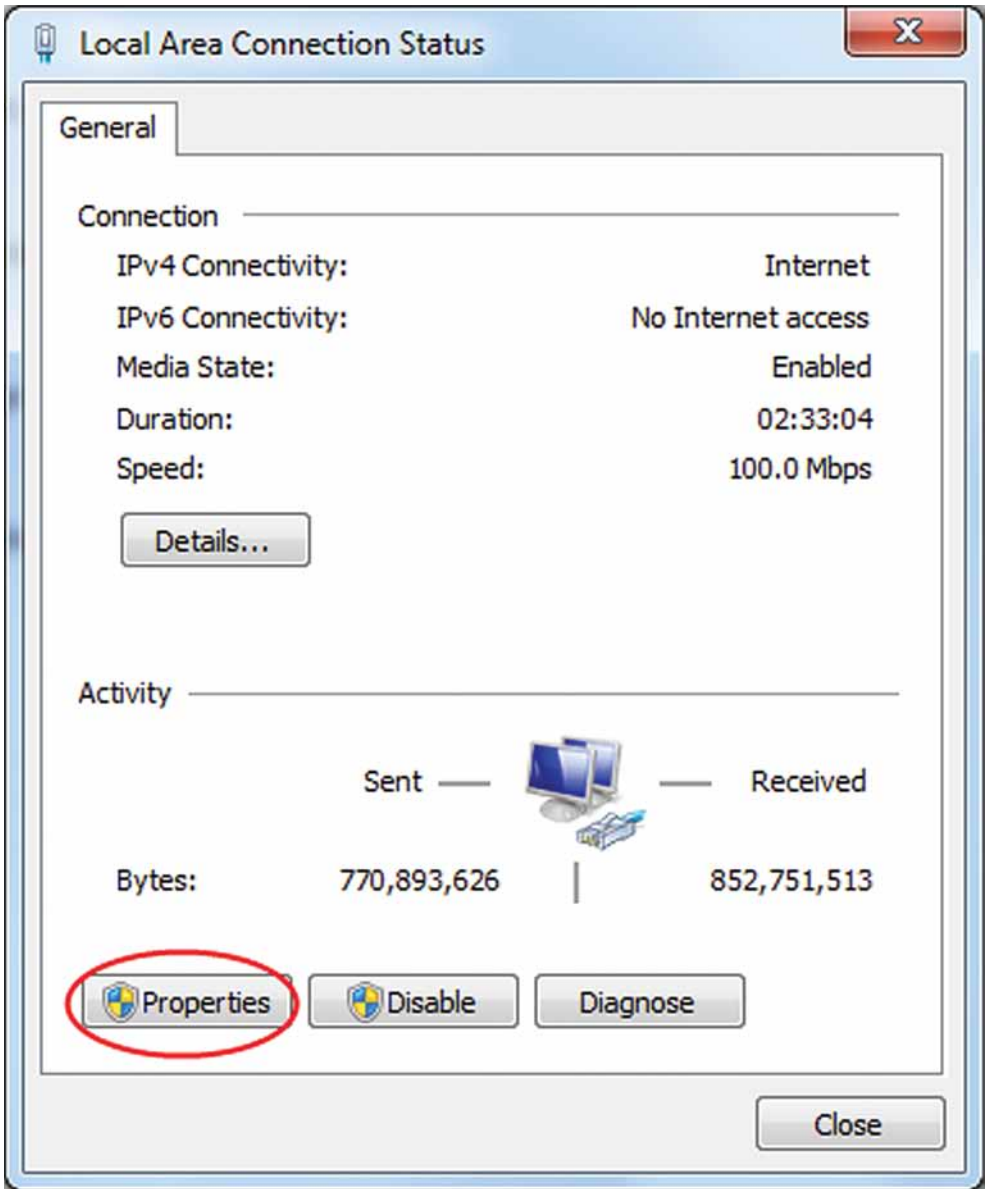

Step 5.

In the page name Local Area Connection Properties, Select the line marked “Internet Protocol Version 4(TCP/IPv4)” Then click on the button marked “Properties”

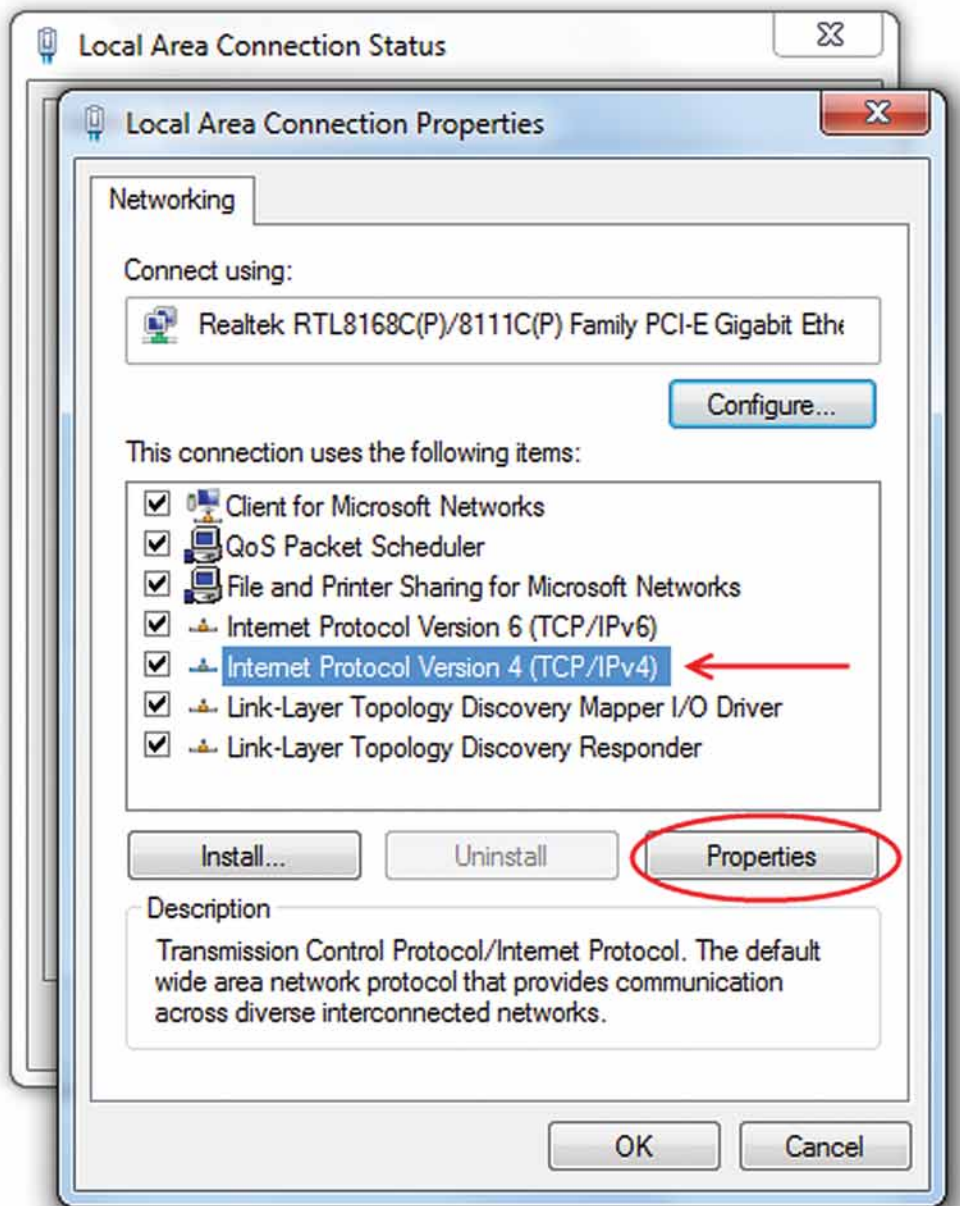

Step 6.

In the page Internet Protocol Version 4(TCP/IPv4) properties”, Select the radio button marked “Use the following IP address”

Type in the address 192.168.1.1

Type in the subnet mask 255.255.255.0

Click Ok.

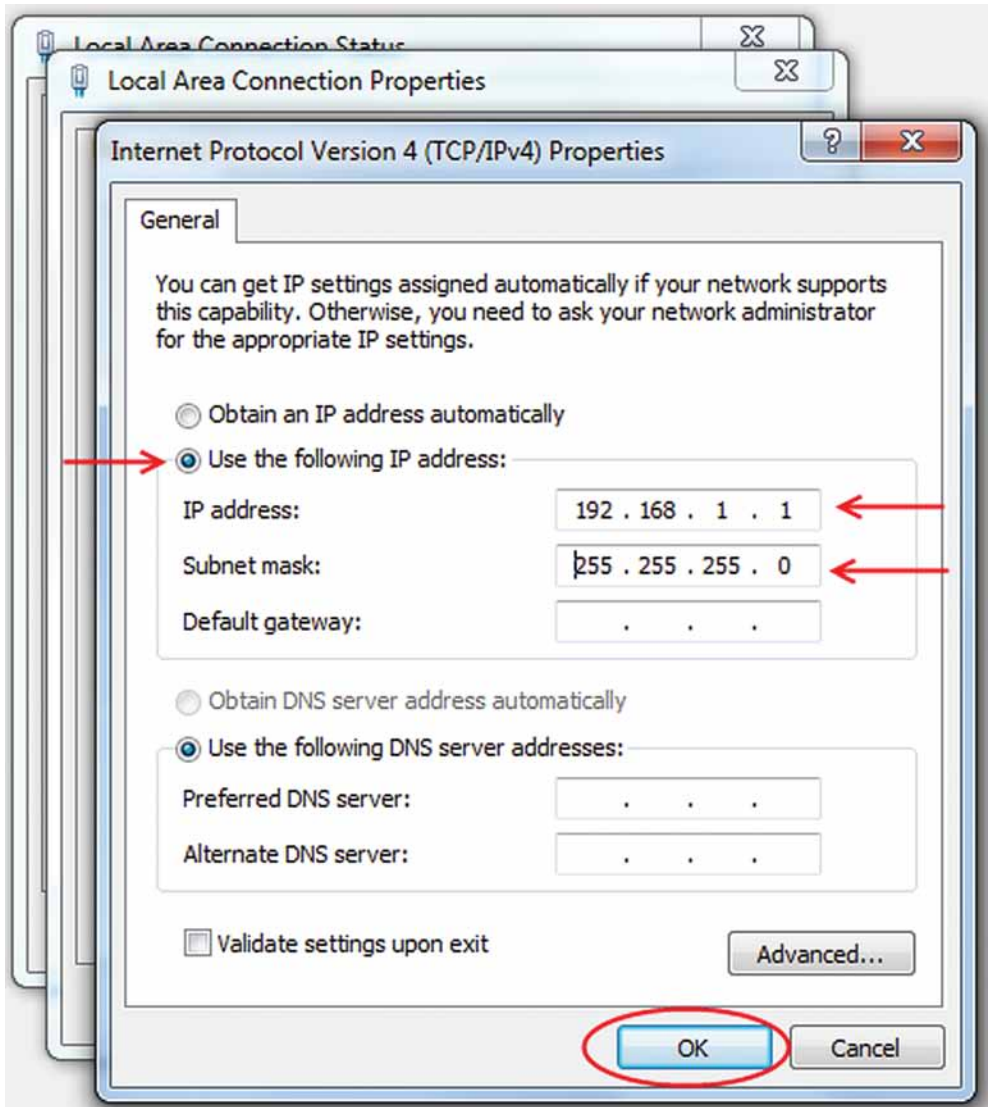

Step 7:

Disconnect your computer from the network and connect to the Console using the black cross-over Ethernet cable supplied with the LWS MkIII Console.

Step 8:

Your computer has now been assigned the IP Address of 192.168.1.1 and can now access the LWS console in a Firefox or Internet Explorer web-browser by entering the address 192.168.1.90 into the address bar. You will now be able to access the Settings Page of the Console.

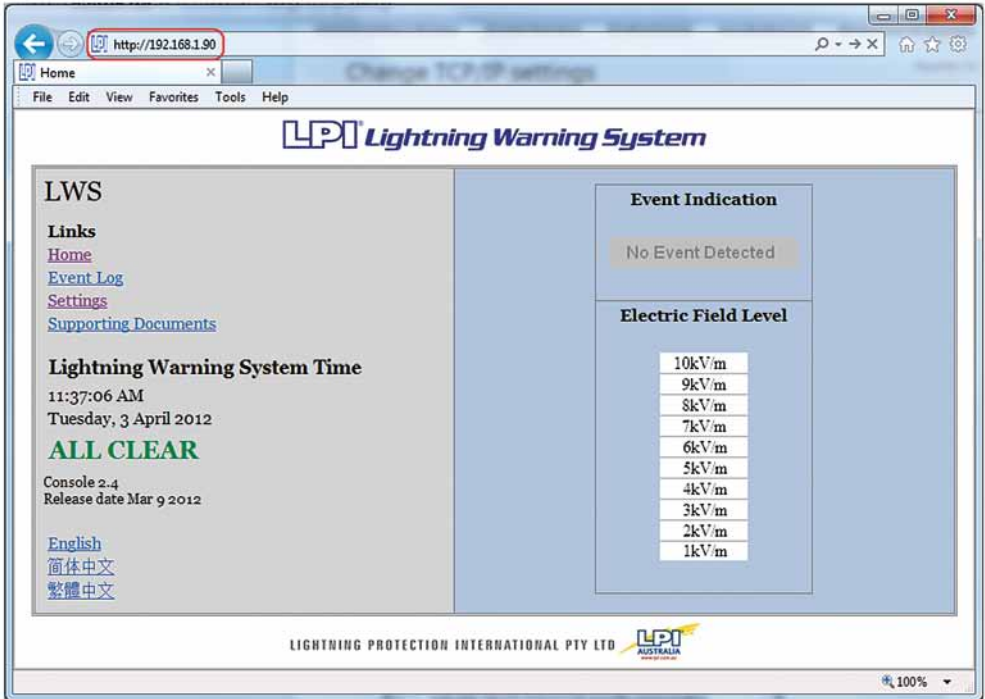

The page should render like the diagram.

At this point you should have established communication with the LWS via a direct connection.

How to put LWS onto a Network

To put the LWS on a Local Area Network (LAN) you will need some help from the Network Administrator.

You will need to know whether the Administrator wants you to use a fixed IP address or use DHCP to assign your network settings.

The easiest way to do this is use an IP setup tool that can be provided by LPI. Ask us and we can email it to you. Otherwise follow the steps below.

Initially

Establish communications with the LWS, by following directions in the section named “Establishing a LAN Connection to the LWS Console”.

If using DHCP follow these steps

Step 1

Browse the Settings Page

Step 2

Click button marked Enter Manual IP Address (Even for DHCP)

Step 3

Click button marked Automatic

Step 4

Connect LWS and your PC to the network using the Blue (straight through) network cables.

Step 5

Turn off LWS and wait a few seconds and then turn it back on.

Step 6

Get the network administrator to put your PC back on to the network.

Step 7

Ask your network administrator what address the LWS has been assigned and then browse to it. Add this page to your favourites or bookmarks, so that other users can find it easily.

LWS

Links

[Home](#)

[Event Log](#)

[Settings](#)

[Supporting Documents](#)

Current IP Address:

192.168.116.86

Current IP Mask:

255.255.255.0

Current Gateway Address:

192.168.116.254

Current DNS Address:

192.168.116.1

Warning by changing the IP Address you may be unable to view the LWS web pages. Please ensure that the correct IP Address is set

[English](#)

[简体中文](#)

[繁體中文](#)

Set IP address Manual or Automatic

Enter Manual IP Address:

Enter Manual IP Mask (typically 255.255.255.0):

Enter Manual Gateway Address:

Enter Manual DNS Address:

Set

Automatically get IP Addresses from a connected DHCP server

Automatic

If using a Static IP follow these steps

Step 1

Browse the Settings Page

Step 2

Click button marked Enter Manual IP Address (Even for DHCP)

Step 3

Ask your network administrator what IP address to use and what IP mask to use.

Step 4

Insert the values given by the network administrator into the text boxes on the page. You don't need to worry about the Gateway and the DNS address, just leave them blank.

Step 5

Make sure the format has the full stops and double check they are correct. Write down this address.

Step 6

Press the button marked Set.

Step 7

Connect LWS and your PC to the network using the Blue (straight through) network cables.

Step 8

Turn off LWS and wait a few seconds and then turn it back on.

Step 9

Get the network administrator to put your PC back on to the network.

Step 10

Browse to the address that you assigned to the LWS. Add this page to your favourites or bookmarks, so that other users can find it easily.

General Browser Settings

Whether you are using Internet Explorer, Firefox, Safari or Chrome as your browser there are a couple of settings that your browser needs to communicate successfully with the LWS. Javascript must be turned on for this website. The character encoding should be UTF-8 or Auto-Detect.

These settings are generally turned on anyway so generally you don't have to change anything here.

Relay / Alarm Output and Power Connectors

The Pin Connections for Sensor Assembly Plugs are as shown in the following diagram.

Diagrams show pin connections looking towards front of plugs

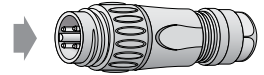

Alarm Relay and Power Connectors (Sensor and Range Extenders)

4 PIN MALE

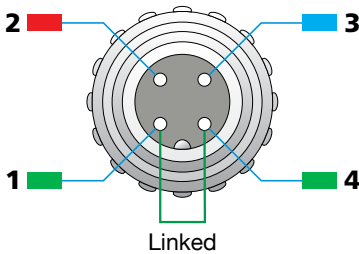

- 1 = DC (-)
- 2 = DC (+)
- 3 = SOLAR (+)
- 4 = DC (-)

7 PIN FEMALE (Covered)

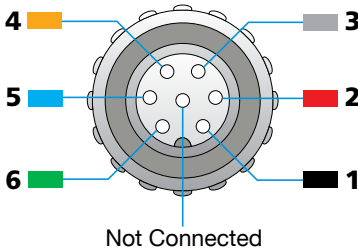

- 1 = DC (-)
- 2 = DC (+)
- 3 = WARNING NO
- 4 = WARNING COMMON
- 5 = WARNING NC
- 6 = Not Connected

7 PIN MALE (Siren Connector)

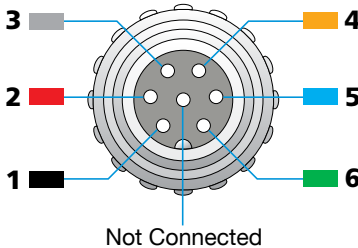

- 1 = DC (-)
- 2 = DC (+)
- 3 = ALL CLEAR NO
- 4 = ALL CLEAR COMMON
- 5 = ALARM NO
- 6 = ALARM COMMON

Note: All Sensor and Range Extender DC Outputs are 12V with maximum current of 250mA. Relays are capable of switching 120Vac at up to 1A. Console Relays are capable of switching 120Vac at up to 1A.

Maintenance Check Recommendations

A maintenance check should be conducted every 3 months, if a communications error is displayed or if the system is suspected of not recording obvious lightning events.

Sensors and Range Extenders

- Check for physical damage to exterior of Assembly.
- Check for physical damage to Cables (Power and Siren cables).
- For Sensors check for damage to electric field sensing needle at top of sensing antenna. If damaged (bent) or missing please contact local LPI distributor for an approved replacement.
- For Sensors check that earth rod is still installed correctly and earth cable from Sensor is still connected.
- Check condition of Fuse (Package A: inside power supply enclosure, Package B: inside battery box).
- Disconnect and reconnect power to the Sensor/Range Extender.

Console

- Check Red power LED is on.
- Check that Communications Antenna has line of sight to the nearest Sensor or Range Extender.
- Check that the Ethernet Cable is correctly inserted in the Console Ethernet socket, and that the Ethernet cable is still connected to a computer or network switch at the other end.
- Check that the green network lights are on, they indicate that the network cable is actually connected to a network.
- In settings page re-confirm settings (e.g. System Time, Indication Duration, All Clear Time-out Period and Alarm Enable Times).
- Test Alarm Sounding Operation (in Alarm Override page). Ensure that all personnel are aware of imminent test before hand, to avoid unnecessary confusion.

Supporting Documents

Links to a software copy of the Installation and Operating Manual, Technical Data Sheet and to the Brochures (English and Chinese) can be accessed by browsing to “Supporting Documents” from the Links list.

The documents have short names, here is an explanation of them.

LOG.TXT: Your log file.

INST&OP.PDF: The electronic version of the Installation and Operation Manual.

TDS.PDF: The Technical Data sheet for the LWS

BROCHCH.PDF: The Brochure for the LWS (chinese)

BROCHE.PDF The Brochure for the LWS (english)



LWS Links Home Event Log Settings Supporting Documents English 简体中文 繁體中文	Files LOG.TXT INST&OP.PDF TDS.PDF BROCHCH.PDF BROCHE.PDF
--	--



Optional Extras

- Wireless Range Extenders (with Alarm Relay Outputs), available in solar panel or power supply configuration. (Maximum 10)
- Sirens for Range Extenders
- High powered/Industrial Siren
- Wired version of LWS. Communications between the Console and the Sensor are wired through a coaxial cable instead of wirelessly. The upper range limit of this cable is about 50m. The wired version does not allow for range extenders to be used with the system.

Troubleshooting

Checking Power

When power is initially connected to the Sensor or Range Extenders a “Power On Self Test” is performed. Successful power on and start up is indicated by switching the Alarm Output Relays on in sequence (Warning, Alarm, All Clear). If the Alarm Output Relays are not enabled this indicates a fault has occurred with the Power Supply or with the Sensor or Range Extender itself. If this occurs check that power is being supplied to the Sensor or Range Extender, if power is being supplied as expected please contact your LPI distributor.

Checking Network

You should be able to browse to the console by going to a favourite or bookmark. That should have been set up in “Establishing Connectivity to the LWS”.

If you can browse to this page then communications between your PC and the LWS console are ok.

Checking Communications to Sensor

Browse to settings and then click the button marked System Status.

Check to see that all your LWS entities are listed, ie. Sensor, Console and each range extender.

LPI Lightning Warning System

LWS

Links

- [Home](#)
- [Event Log](#)
- [Settings](#)
- [Supporting Documents](#)

Lightning Warning System Time

3:43:31 PM
Friday, 30 March 2012

ALL CLEAR

Entity	Voltage (volts)	Signal (dbm)	Comms
Console	6.0	-62	OK
Sensor	13.75	-63	OK

Console 2.4
Release date Mar 9 2012

[English](#)
[简体中文](#)
[繁體中文](#)

Event Indication

No Event Detected

Electric Field Level

- 10kV/m
- 9kV/m
- 8kV/m
- 7kV/m
- 6kV/m
- 5kV/m
- 4kV/m
- 3kV/m
- 2kV/m
- 1kV/m

Check that communications to all units are listed as OK.

Check that all voltages except console are above 11.3 volts and are green. If this is not the case you have to investigate why, possibly the solar panel is not charging. LPI can help you with this, please contact us.

Check that all signal strengths are closer to zero than -85db.

If this is not the case you have to investigate why, it might be that something is blocking the radio communications, the units may have to be repositioned. If the signal strength is between -85 and -105 db then communication may be intermittent.

If the voltages or the signal strengths occasionally go red but come back green or orange in a minute or two, this is nothing to worry about, This happens occasionally it is just a packet dropout.

Checking Siren Functionality

In the situation of lightning events being detected, displayed and logged, but no Alarm or All Clear sirens being sounded and no Alarms activated when using Alarm Reassert buttons, please check that the System Time and Alarm Enable/Disable Times (see “Changing the Settings: System Time” and “Changing the Settings: Alarm Enable Times”) are set correctly. If the Current system time is outside the Alarm Enable Times then the Alarm Relay Outputs will not be activated (and therefore no Siren Sounded). If problems still occur please contact your LPI Distributor.

Error Messages

If something does go wrong with the LWS and the console can't communicate with the Sensor, then an appropriate message is displayed, in RED, on the Home Page.

Please don't ignore this but try to find the cause of the problem.

Possible causes of this type of problem is:

- a loss of power on the Sensor,
- a bad radio path to Sensor
- a loss of a critical range extender
- a broken or damaged antenna cable near the console.

If you can't resolve the problem yourself contact your LPI distributor for assistance.

Specifications

Control Console

Enclosure:	Die-cast, 170mm (L) x 120mm (W) x 50mm (H)
Control:	Micro Processor
Interface:	Webpage (default address 192.168.1.90)
Operation:	Console receives Electrostatic Field measurements and event notification from sensors in the field and displays received information on an easy to read webpage. Allows users to download and save a log of events that have occurred. Allows users to change a range of settings.
Relay Output:	3 Outputs (All Clear, Warning and Alarm. 1 amp, 24Vdc or 120Vac)
Weight:	840g
Colour:	Grey
Power Supply:	6V plug pack (110V-240V)
Wireless Frequency:	2.4GHz

Sensor Assembly

Construction:	Stainless Steel
Lightning Discharge Detection Range:	Far Strikes, Approx 10-25km Near Strikes, < Approx 10km
Electric Field Measurement:	Negligible, Approx ± 0 -3kV/m Low E-Field, Approx ± 3 -7kV/m High E-Field, Approx ± 7 -10kV/m
Relay Output:	3 Outputs (All Clear, Warning and Alarm. 1 amp, 24Vdc or 120Vac)
Wireless Frequency:	2.4GHz
Colour:	Stainless Steel
Weight:	8kg
Power Supply:	Package A 110V-240V, UPS 3 hours uptime. Package B 12Vdc Solar Panel and storage battery
Siren:	10W, 8 ohm approximately 117dbm.

Solar Panel

Voltage:	12V
Power:	20W
Size:	639 x 294 x 23mm
Weight:	2.4kg
Type:	Monocrystalline



Lightning Protection International Pty Ltd

ABN 11 099 190 897

PO Box 379 Kingston, Tasmania, Australia, 7051

■ Phone: +61 3 62271955 ■ Email: info@lpi.com.au

■ Fax: +61 3 62291900 ■ Web: www.lpi.com.au

